

Contents

HP E1333A Universal Counter Service Manual

Edition 4

[Click here to Return to HP TS-5400 Systems On-Line Manuals Main Contents](#)

Warranty	5
WARNINGS	6
Safety Symbols	6
Declaration of Conformity	7
Reader Comment Sheet	9
Manual Overview	11
Manual Content	11
Chapter 1. General Information	13
Introduction	13
Safety Considerations	14
WARNINGS and CAUTIONS	14
Counter Description	16
Counter Specifications	17
Counter Serial Numbers	17
Counter Options	17
Recommended Test Equipment	18
Chapter 2. Installation	19
Introduction	19
Initial Inspection	19
Preparation for Use	19
Shipping Guidelines	20
Chapter 3. Operating Instructions	21
Introduction	21
Counter Operation	21
Preventive Maintenance	21
WARNINGS and CAUTIONS	22
Cleaning Procedure	22
Operator's Check	23
Self-Test Procedure	23
Example: Counter Self-Test	23
Chapter 4. Verification Tests	25
Introduction	25
Test Conditions and Procedures	25
Performance Test Record	25
Verification Test Examples	26
Functional Verification Tests	27
Counter Self-Test	27
Totalizing Measurement Test	27

Ratio Measurements Test	29
Trigger Level Test	31
Operation Verification Tests	34
Performance Verification Tests	35
Frequency Measurements Test	35
Test Procedure	37
Period Average Measurements Test	40
Test Procedure	41
Pulse Width Measurements Test	43
Time Interval Measurements Test	46
Performance Test Record	49
Chapter 5. Adjustments	55
Introduction	55
Adjustment Requirements	55
Adjustment Access	55
Reference Oscillator Adjustment	56
Trigger Level Zero Adjustments	57
Chapter 6. Replaceable Parts	61
Introduction	61
Exchange Assemblies	61
Ordering Information	61
Replaceable Parts List	62
Chapter 7. Service	65
Introduction	65
Equipment Required	65
Service Aids	65
Troubleshooting Techniques	66
Identifying the Problem	66
Testing the Counter	67
Repair/Maintenance Guidelines	68
ESD Precautions	68
Post-Repair Safety Checks	69
Appendix A. Counter Accuracy Calculations	71
Introduction	71
Calculating Counter Accuracy	71
Frequency Measurements Trigger Noise Error	73
Period Measurements Trigger Noise Error	74
Counter Accuracy Equations Table	74
Accuracy Calculations Examples	75
Example: Calculating Frequency Accuracy	75
Effects of Varying Signal Conditions	76
Example: Calculating Period Average Accuracy	77
Effects of Varying Signal Conditions	78
Counter Accuracy Programs	79
Frequency Measurement Accuracy	79
Period Measurements Accuracy	80

Appendix B. Verification Tests - C Programs	83
Functional Verification Tests	83
Operator's Check	83
Totalizing Measurement Test	84
Ratio Measurements Test	85
Trigger Level Test	87
Performance Verification Tests	89
Frequency Measurements Test	89
Period Average Measurements	90
Pulse Width Measurements Test	92
Time Interval Measurements Test	93
Counter Accuracy Programs	95
Frequency Measurement Accuracy	95
Period Measurements Accuracy	96

Notes

Certification

Hewlett-Packard Company certifies that this product met its published specifications at the time of shipment from the factory. Hewlett-Packard further certifies that its calibration measurements are traceable to the United States National Institute of Standards and Technology (formerly National Bureau of Standards), to the extent allowed by that organization's calibration facility, and to the calibration facilities of other International Standards Organization members.

Warranty

This Hewlett-Packard product is warranted against defects in materials and workmanship for a period of three years from date of shipment. Duration and conditions of warranty for this product may be superseded when the product is integrated into (becomes a part of) other HP products. During the warranty period, Hewlett-Packard Company will, at its option, either repair or replace products which prove to be defective.

For warranty service or repair, this product must be returned to a service facility designated by Hewlett-Packard (HP). Buyer shall prepay shipping charges to HP and HP shall pay shipping charges to return the product to Buyer. However, Buyer shall pay all shipping charges, duties, and taxes for products returned to HP from another country.

HP warrants that its software and firmware designated by HP for use with a product will execute its programming instructions when properly installed on that product. HP does not warrant that the operation of the product, or software, or firmware will be uninterrupted or error free.

Limitation Of Warranty

The foregoing warranty shall not apply to defects resulting from improper or inadequate maintenance by Buyer, Buyer-supplied products or interfacing, unauthorized modification or misuse, operation outside of the environmental specifications for the product, or improper site preparation or maintenance.

The design and implementation of any circuit on this product is the sole responsibility of the Buyer. HP does not warrant the Buyer's circuitry or malfunctions of HP products that result from the Buyer's circuitry. In addition, HP does not warrant any damage that occurs as a result of the Buyer's circuit or any defects that result from Buyer-supplied products.

NO OTHER WARRANTY IS EXPRESSED OR IMPLIED. HP SPECIFICALLY DISCLAIMS THE IMPLIED WARRANTIES OF MERCHANTABILITY AND FITNESS FOR A PARTICULAR PURPOSE.

Exclusive Remedies

THE REMEDIES PROVIDED HEREIN ARE BUYER'S SOLE AND EXCLUSIVE REMEDIES. HP SHALL NOT BE LIABLE FOR ANY DIRECT, INDIRECT, SPECIAL, INCIDENTAL, OR CONSEQUENTIAL DAMAGES, WHETHER BASED ON CONTRACT, TORT, OR ANY OTHER LEGAL THEORY.

Notice

The information contained in this document is subject to change without notice. HEWLETT-PACKARD (HP) MAKES NO WARRANTY OF ANY KIND WITH REGARD TO THIS MATERIAL, INCLUDING, BUT NOT LIMITED TO, THE IMPLIED WARRANTIES OF MERCHANTABILITY AND FITNESS FOR A PARTICULAR PURPOSE. HP shall not be liable for errors contained herein or for incidental or consequential damages in connection with the furnishing, performance or use of this material. This document contains proprietary information which is protected by copyright. All rights are reserved. No part of this document may be photocopied, reproduced, or translated to another language without the prior written consent of Hewlett-Packard Company. HP assumes no responsibility for the use or reliability of its software on equipment that is not furnished by HP.

U.S. Government Restricted Rights

The Software and Documentation have been developed entirely at private expense. They are delivered and licensed as "commercial computer software" as defined in DFARS 252.227-7013 (Oct 1988), DFARS 252.211-7015 (May 1991) or DFARS 252.227-7014 (Jun 1995), as a "commercial item" as defined in FAR 2.101(a), or as "Restricted computer software" as defined in FAR 52.227-19 (Jun 1987) (or any equivalent agency regulation or contract clause), whichever is applicable. You have only those rights provided for such Software and Documentation by the applicable FAR or DFARS clause or the HP standard software agreement for the product involved.



HP E1333A 3-Channel Universal Counter Service Manual
Edition 4

Copyright © 1996 Hewlett-Packard Company. All Rights Reserved.

Documentation History

All Editions and Updates of this manual and their creation date are listed below. The first Edition of the manual is Edition 1. The Edition number increments by 1 whenever the manual is revised. Updates, which are issued between Editions, contain replacement pages to correct or add additional information to the current Edition of the manual. Whenever a new Edition is created, it will contain all of the Update information for the previous Edition. Each new Edition or Update also includes a revised copy of this documentation history page.

Edition 1 (Part Number E1333-90010)..... April 1991
Edition 2 (Part Number E1333-90011)..... March 1992
Edition 3 (Part Number E1333-90012)..... June 1996
Edition 4 (Part Number E1333-90013)..... December 1996

Safety Symbols



Instruction manual symbol affixed to product. Indicates that the user must refer to the manual for specific WARNING or CAUTION information to avoid personal injury or damage to the product.



Indicates the field wiring terminal that must be connected to earth ground before operating the equipment—protects against electrical shock in case of fault.

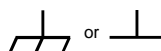

Frame or chassis ground terminal—typically connects to the equipment's metal frame.



Alternating current (AC).



Direct current (DC).



Indicates hazardous voltages.

WARNING

Calls attention to a procedure, practice, or condition that could cause bodily injury or death.

CAUTION

Calls attention to a procedure, practice, or condition that could possibly cause damage to equipment or permanent loss of data.

WARNINGS

The following general safety precautions must be observed during all phases of operation, service, and repair of this product. Failure to comply with these precautions or with specific warnings elsewhere in this manual violates safety standards of design, manufacture, and intended use of the product. Hewlett-Packard Company assumes no liability for the customer's failure to comply with these requirements.

Ground the equipment: For Safety Class 1 equipment (equipment having a protective earth terminal), an uninterruptible safety earth ground must be provided from the mains power source to the product input wiring terminals or supplied power cable.

DO NOT operate the product in an explosive atmosphere or in the presence of flammable gases or fumes.

For continued protection against fire, replace the line fuse(s) only with fuse(s) of the same voltage and current rating and type. DO NOT use repaired fuses or short-circuited fuse holders.

Keep away from live circuits: Operating personnel must not remove equipment covers or shields. Procedures involving the removal of covers or shields are for use by service-trained personnel only. Under certain conditions, dangerous voltages may exist even with the equipment switched off. To avoid dangerous electrical shock, DO NOT perform procedures involving cover or shield removal unless you are qualified to do so.

DO NOT operate damaged equipment: Whenever it is possible that the safety protection features built into this product have been impaired, either through physical damage, excessive moisture, or any other reason, REMOVE POWER and do not use the product until safe operation can be verified by service-trained personnel. If necessary, return the product to a Hewlett-Packard Sales and Service Office for service and repair to ensure that safety features are maintained.

DO NOT service or adjust alone: Do not attempt internal service or adjustment unless another person, capable of rendering first aid and resuscitation, is present.

DO NOT substitute parts or modify equipment: Because of the danger of introducing additional hazards, do not install substitute parts or perform any unauthorized modification to the product. Return the product to a Hewlett-Packard Sales and Service Office for service and repair to ensure that safety features are maintained.

Declaration of Conformity
according to ISO/IEC Guide 22 and EN 45014

Manufacturer's Name: Hewlett-Packard Company
Loveland Manufacturing Center

Manufacturer's Address: 815 14th Street S.W.
Loveland, Colorado 80537

declares, that the product:

Product Name: 3-Channel Universal Counter

Model Number(s): HP E1333A

Product Options: All

conforms to the following Product Specifications:

Safety: IEC 348:1978/HD 401 S1:1981
CSA 556B
UL 1244

EMC: CISPR 11:1990/EN55011 (1991): Group1 Class A
EN50082-1:1992
IEC 801-2:1991: 4kVCD, 8kVAD
IEC 801-3:1984: 3 V/m
IEC 801-4:1988: 1kV Power Line
0.5kV Signal Lines

Supplementary Information: The product herewith complies with the requirements of the Low Voltage Directive 73/23/EEC and the EMC Directive 89/336/EEC and carries the "CE" marking accordingly.

Safety qualification performed February, 1989.
Tested in a typical HP B-size VXI configuration.

September 5, 1996

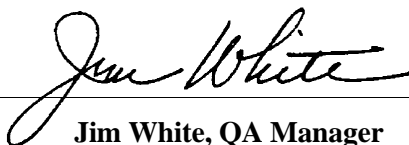

Jim White, QA Manager

European contact: Your local Hewlett-Packard Sales and Service Office or Hewlett-Packard GmbH, Department HQ-TRE, Herrenberger Straße 130, D-71034 Böblingen, Germany (FAX +49-7031-143143).

Notes

Please fold and tape for mailing

Reader Comment Sheet

HP E1333A 3-Channel Universal Counter Service Manual
Edition 4

You can help us improve our manuals by sharing your comments and suggestions. **In appreciation of your time, we will enter you in a quarterly drawing for a Hewlett-Packard Palmtop Personal Computer** (U.S. government employees cannot participate in the drawing).

_____ Your Name	_____ City, State/Province
_____ Company Name	_____ Country
_____ Job Title	_____ Zip/Postal Code
_____ Address	_____ Telephone Number with Area Code

Please list the system controller, operating system, programming language, and plug-in modules you are using.

fold here

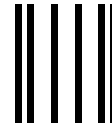

NO POSTAGE
NECESSARY
IF MAILED
IN THE
UNITED STATES



POSTAGE WILL BE PAID BY ADDRESSEE

HEWLETT-PACKARD COMPANY
Measurement Systems Division
Learning Products Department
P.O. Box 301
Loveland, CO 80539-9984

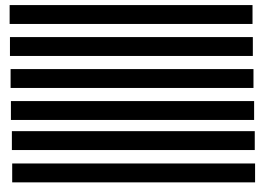

cut along this line



fold here

Please pencil-in one circle for each statement below:

- The documentation is well organized.
- Instructions are easy to understand.
- The documentation is clearly written.
- Examples are clear and useful.
- Illustrations are clear and helpful.
- The documentation meets my overall expectations.

Disagree	←————→				Agree
<input type="radio"/>	<input type="radio"/>	<input type="radio"/>	<input type="radio"/>	<input type="radio"/>	<input type="radio"/>
<input type="radio"/>	<input type="radio"/>	<input type="radio"/>	<input type="radio"/>	<input type="radio"/>	<input type="radio"/>
<input type="radio"/>	<input type="radio"/>	<input type="radio"/>	<input type="radio"/>	<input type="radio"/>	<input type="radio"/>
<input type="radio"/>	<input type="radio"/>	<input type="radio"/>	<input type="radio"/>	<input type="radio"/>	<input type="radio"/>
<input type="radio"/>	<input type="radio"/>	<input type="radio"/>	<input type="radio"/>	<input type="radio"/>	<input type="radio"/>

Please write any comments or suggestions below--be specific.

What's in This Manual

Manual Overview

This manual shows how to service the HP E1333A 3-Channel Universal Counter. Additional manuals which may be required for servicing the counter include the *HP E1333A User's Manual* which contains counter operation, installation, and configuration information, and the appropriate mainframe user's manual(s) for mainframe operation, installation and configuration information.

Manual Content

Chapter	Title	Content
1	General Information	Provides a basic description, and lists available options and accessories. Also lists the tools and test equipment required for service.
2	Installation	Procedures to install the counter, perform initial inspection, prepare for use, and store and ship the counter.
3	Operating Instructions	Procedures to operate the counter, perform scheduled preventive maintenance, and perform operator's check.
4	Verification Tests	Functional verification, operation verification, and performance verification tests to test the counter.
5	Adjustments	Procedures to adjust the counter to within its rated specifications.
6	Replaceable Parts	Lists part numbers for user replaceable parts in the counter. Provides information on ordering spare parts and module/assembly exchange.
7	Service	Procedures to aid in fault isolation and repair of the counter.
Appx A	Calculating Multimeter Accuracy	Shows how counter accuracy is defined and calculated.
Appx B	Verification Tests - C Programs	Gives C Program Examples to do the Verification Tests in Chapter 3 and Chapter 4.

Introduction

This HP E1333A Service Manual contains information required to test, adjust, troubleshoot, and repair the HP E1333A B-Size VXI 3-Channel Universal Counter. See the *HP E1333A User's Manual* for additional information. Figure 1-1 shows the HP E1333A counter.

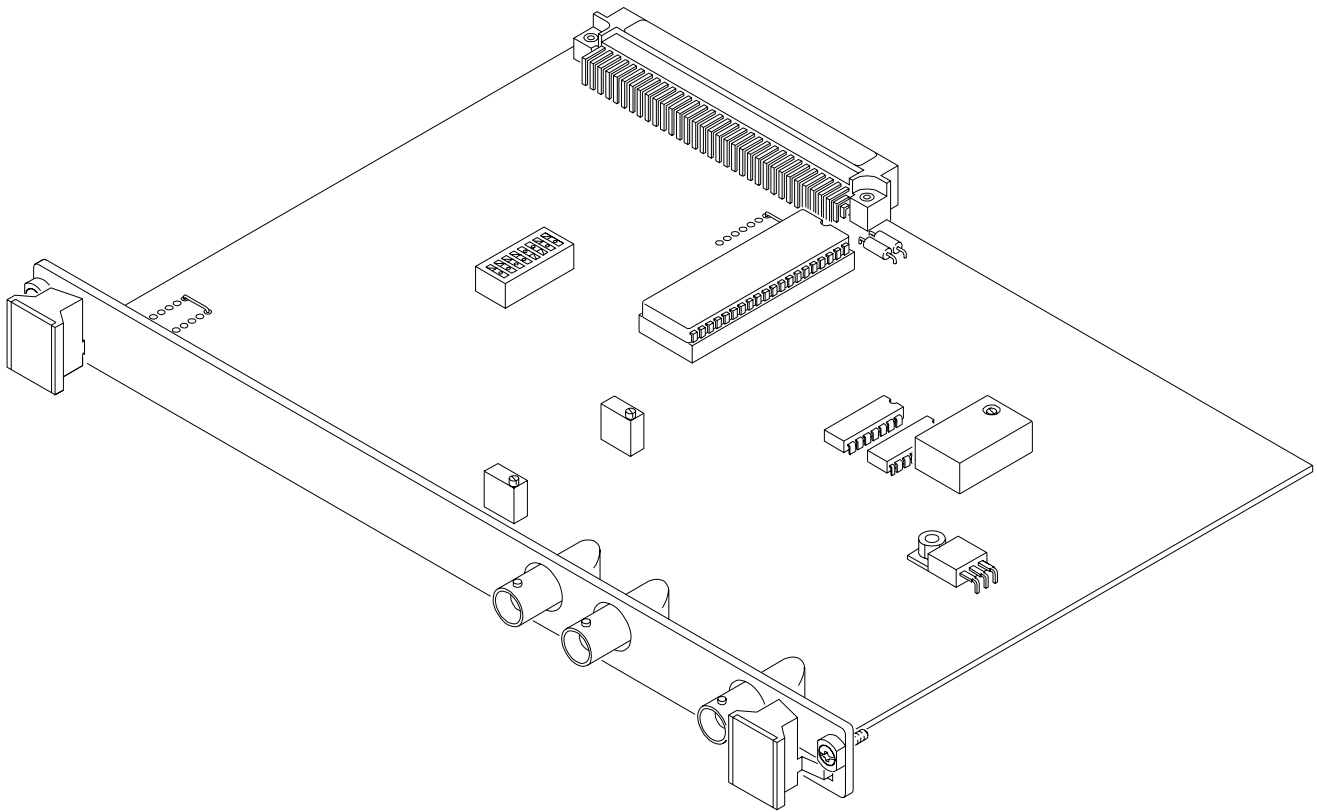

Figure 1-1. HP E1333A 3-Channel Counter

Safety Considerations

This product is a Safety Class I instrument that is provided with a protective earth terminal when installed in the mainframe. The mainframe, counter, and all related documentation should be reviewed for familiarization with safety markings and instructions before operation or service.

Refer to the WARNINGS on page 3 in this manual for a summary of safety information. Safety information for preventive maintenance, testing, adjusting, and service follows and is also found throughout this manual.

WARNINGS and CAUTIONS

This section contains WARNINGS which must be followed for your protection and CAUTIONS which must be followed to avoid damage to the equipment when performing instrument maintenance or repair.

WARNING

SERVICE-TRAINED PERSONNEL ONLY. The information in this manual is for service-trained personnel who are familiar with electronic circuitry and are aware of the hazards involved. To avoid personal injury or damage to the instrument, do not perform procedures in this manual or do any servicing unless you are qualified to do so.

CHECK MAINFRAME POWER SETTINGS. Before applying power, verify that the mainframe setting matches the line voltage and the correct fuse is installed. An uninterruptible safety earth ground must be provided from the main power source to the mainframe input wiring terminals, power cord, or supplied power cord set.

GROUNDING REQUIREMENTS. Interruption of the protective (grounding) conductor (inside or outside the mainframe) or disconnecting the protective earth terminal will cause a potential shock hazard that could result in personal injury. (Grounding one conductor of a two-conductor outlet is not sufficient protection.)

COMMON GROUND. Verify that a common ground exists between the unit under test and the counter (via the mainframe) prior to energizing either unit.

IMPAIRED PROTECTION. Whenever it is likely that instrument protection has been impaired, the mainframe must be made inoperative and be secured against any unintended operation.

REMOVE POWER IF POSSIBLE. Some procedures in this manual may be performed with power supplied to the mainframe while protective covers are removed. Energy available at many points may, if contacted, result in personal injury. (If maintenance can be performed without power applied, the power should be removed.)

USING AUTOTRANSFORMERS. If the mainframe is to be energized via an autotransformer (for voltage reduction) make sure the common terminal is connected to neutral (that is, the grounded side of the main's supply).

WARNING **CAPACITOR VOLTAGES.** Capacitors inside the mainframe may remain charged even when the mainframe has been disconnected from its source of supply.

USE PROPER FUSES. For continued protection against fire hazard, replace the line fuse(s) only with fuses of the same current rating and type (such as normal blow, time delay, etc.). Do not use repaired fuses or short-circuited fuseholders.

CAUTION **MAXIMUM VOLTAGE.** Maximum voltage that may be applied between any BNC connector is 42 V for the 1 M Ω input impedance (Channels 1 and 2) and 5 V for the 50 Ω input impedance (Channels 1, 2, and 3). In general, the limiting factor is the maximum power which cannot exceed 0.5 W.

STATIC ELECTRICITY. Static electricity is a major cause of component failure. To prevent damage to the electrical components in the counter, observe anti-static techniques when removing a counter from the mainframe or when working on the counter.

Counter Description

The HP E1333A counter is an "instrument" in the slots of a VXibus mainframe. As such, it is assigned an error queue, input and output buffers, status registers, and is allocated a portion of mainframe memory for reading storage.

NOTE Instruments are based on the logical addresses of the plug-in modules. Refer to the configuration guide provided with your system for information on setting the addresses to create an instrument.

There are six HP E1333A counter functions (see Table 1-1):

- Frequency Measurements
- Period Average
- Pulse Width/Pulse Width Average
- Time Interval/Time Interval Average
- Totalize
- Frequency Ratio

Table 1-1. HP E1333A 3-Channel Universal Counter Functions

Function/Feature	Chs	Description
Frequency Measurements	1,2,3	Measure frequency from DC to 100 MHz on Channels 1 and 2. Measure frequency from 75 MHz to 1 GHz on Channel 3
Period Average	1,2	Average from 2 to 65,536 periods of the input signal. Period range is 1 μ sec to 6,871 seconds.
Pulse Width	1,2	Measure positive or negative pulse width of the input signal. Pulse width range is 200 nsec to 6,871 sec.
Time Interval	1,2	Measure the time interval between transitions from one channel to another channel. Range is 200 nsec to 6,871 seconds.
Totalizing	1,2	Count the number of transitions on Channels 1 and 2. Minimum pulse width is 5 nsec. Range is 1 to $2^{36}-1$.
Frequency Ratio	1,2	Measure frequency ratio between Channel 1 and 2 or between Channel 2 and 1. Min pulse width is 5 nsec.
Input Capabilities	1,2	Programmable input coupling, termination, attenuation, low pass filter, and trigger levels.

Counter Specifications

Counter specifications are listed in Appendix A of the *HP E1333A User's Manual*. These specifications are the performance standards or limits against which the instrument may be tested.

Counter Serial Numbers

Counters covered by this manual are identified by a serial number prefix listed on the title page. Hewlett-Packard uses a two-part serial number in the form XXXXAYYYYY, where XXXX is the serial prefix, A is the country of origin (A = USA), and YYYYYY is the serial suffix. The serial number suffix is assigned sequentially to each instrument.

If the serial number prefix of your instrument is greater than the one listed on the title page, a Manual Update (as required) will explain how to adapt this manual to your instrument. If the serial number prefix is lower than the one listed on the title page, information contained in Chapter 7, "Manual Changes," explains how to adapt this manual to your instrument.

Counter Options

There are no electrical or mechanical options available for the HP E1333A counter. However, you can order Option 1BN which provides a MIL-STD-45662A Calibration Certificate, or Option 1BP which provides the Calibration Certificate and measurement data. Contact your nearest Hewlett-Packard Sales and Service Office for information on Options 1BN and 1BP.

Recommended Test Equipment

Table 1-2 lists the test equipment recommended for testing, adjusting and servicing the HP E1333A counter. Essential requirements for each piece of test equipment are described in the Requirements column.

Table 1-2. Recommended Test Equipment

Instrument	Requirements	Recommended Model	Use*
Controller, HP-IB	HP-IB compatibility as defined by IEEE Standard 488-1978 and the identical ANSI Standard MC1.1: SH1, AH1, T2, TEO, L2, LE0, SR0, RL0, PP0, DC0, DT0, and CI, 2, 3, 4, 5	HP 9000 Series 300 or IBM compatible PC with HP BASIC	A,F,O, P,T
Mainframe	Compatible with counter	HP E1300A, E1301A, E1302A, or E1401B/T, E1421A (requires E1405A/B or E1406A)	A,F,O, P,T
Function Generator	0.1 Hz to 10 MHz	HP 3325A	F,O,P
Signal Generator	100 kHz to 1 GHz	HP 8663A	F,O,P
DC Standard	Voltage Range -3.0 V to 30.0 V	Datron 4708 with Option 10	F, O,P
Universal Counter	Frequency Range: 0.1 Hz to 1 GHz Accuracy: At least equal to HP 5334B	HP 5334B with (1.3 GHz) C Channel	O,P
Oscilloscope	Frequency Range: 1 kHz to 100 kHz	HP 54111D	A
Digital Multimeter	General Purpose Voltage and Resistance	HP 3458A	T
*A = Adjustments, F = Functional Verification, O = Operation Verification Tests, P = Performance Verification Tests, T = Troubleshooting			

Introduction

This chapter provides information to install the HP E1333A counter, including initial inspection, preparation for use, environment, storage and shipment.

Initial Inspection

Inspect the shipping container for damage. If the shipping container or cushioning material is damaged, keep the container until the shipment contents have been checked and the instrument has been checked mechanically and electrically. See Chapter 1 (Figure 1-1) for shipment contents. See Chapter 4 for procedures to check electrical performance.

WARNING

To avoid possible hazardous electrical shock, do not perform electrical tests if there are signs of shipping damage to any portion of the outer enclosure (covers, panels, etc.).

If the contents are incomplete, if there is mechanical damage or defect, or if the instrument does not pass the electrical performance tests, notify your nearest Hewlett-Packard Sales and Service Office. If the shipping container is damaged or the cushioning material shows signs of stress, notify the carrier as well as Hewlett-Packard, and keep the shipping materials for the carrier's inspection.

Preparation for Use

See Chapter 2 of the *HP E1333A User's Manual* to prepare the HP E1333A counter for use. See the appropriate mainframe user's manual(s) to prepare your mainframe. If your mainframe is not manufactured by Hewlett-Packard, consult the manufacturer for a list of available manual(s).

Recommended operating environment for the HP E1333A counter is 0°C to +55°C with humidity <65% relative (0°C to +40°C). The instrument should be stored in a clean, dry environment. For storage and shipment, the temperature range is -40°C to +75°C with humidity <65% relative (0°C to +40°C).

Shipping Guidelines

Follow the steps in Figure 2-1 to return the HP E1333A counter to a Hewlett-Packard Sales and Support Office or Service Center.

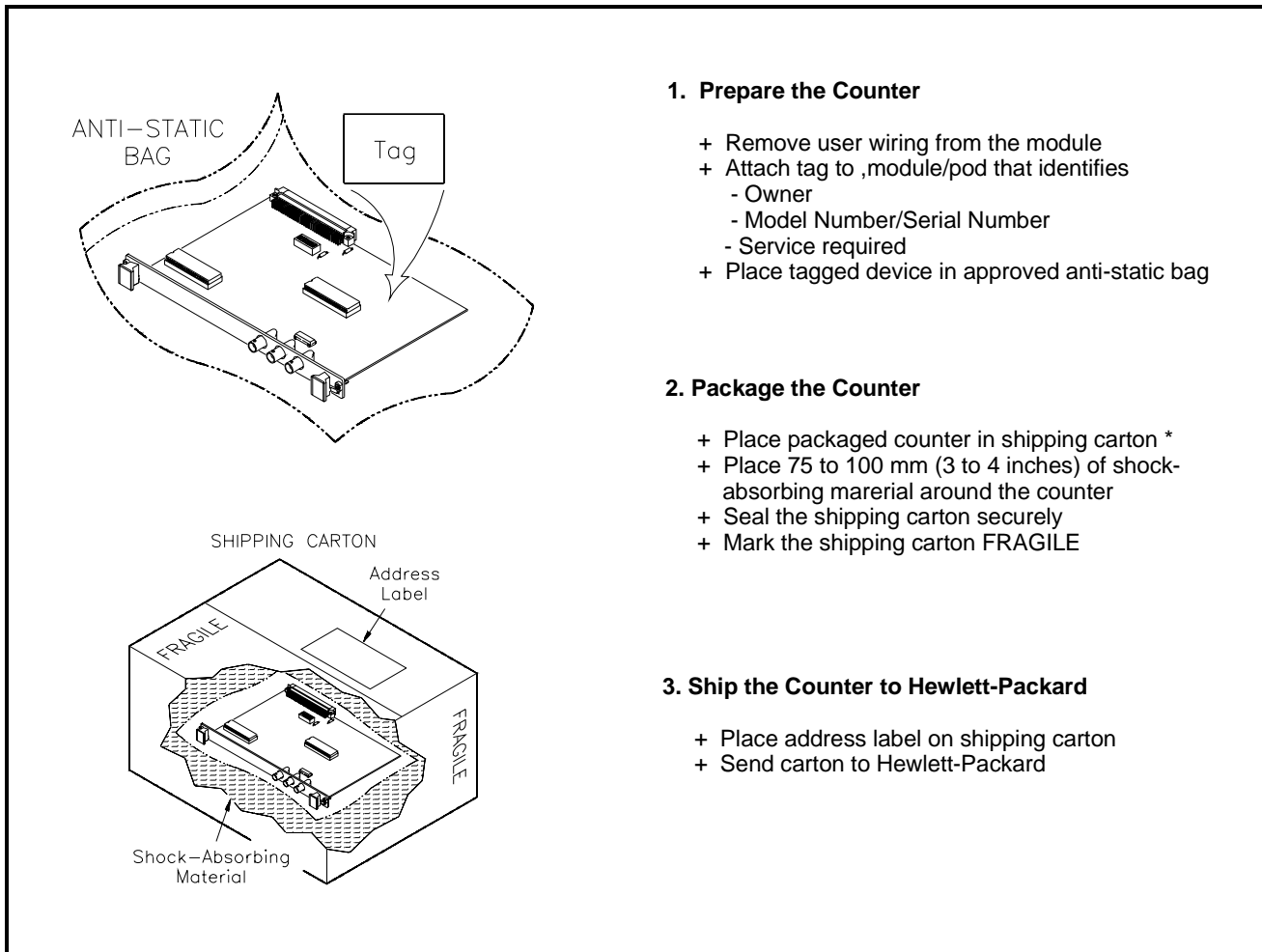

Figure 2-1. Packaging/Shipping Guidelines

* We recommend that you use the same shipping materials as those used in factory packaging (available from Hewlett-Packard). For other (commercially-available) shipping materials, use a double wall-carton with minimum 2.4 MPa (350 psi) test.

Introduction

This chapter lists operating information for the HP E1333A counter, including:

- Counter operation
- Preventive maintenance
- Operator's check (self-test)

Counter Operation

See the *HP E1333A 3-Channel Universal Counter User's Manual* for counter operation, including:

- Getting started
- Configuring the counter
- Using the counter
- Understanding the counter

- Counter command reference
- Counter specifications
- Counter error messages

Preventive Maintenance

Preventive Maintenance for the HP E1333A counter consists of periodically cleaning the counter and then running the Operator's Check (*TST? command). For best results, you should clean the counter once a year or more often if the counter is used in a very dusty or very humid area. See Table 3-1 for recommended cleaning equipment and supplies.

Description	Recommended Use
Soft-bristle brush Mild soap solution Lint-free cloth	Remove dust from printed circuit board Clean faceplate panel Clean faceplate panel

WARNINGS and CAUTIONS

WARNING To eliminate possible electrical shock, disconnect AC power from the mainframe and disconnect all inputs to the counter before removing the counter from the mainframe.

CAUTION Use static control devices (wrist straps, static mats, etc.) when handling the printed circuit assembly. Also, do not use a vacuum cleaner to remove dust from the printer circuit assembly. See Chapter 8, "Service," for electrostatic discharge (ESD) precautions.

Cleaning Procedure Use the following steps to clean the counter:

1. Disconnect any user wiring connected to the input terminals.
2. Remove dust from the printed circuit surface.
3. Clean all contacts indicated in Figure 3-1.
4. Clean the faceplate panel using a lint-free cloth.
5. Reconnect user wiring to the counter input connectors.

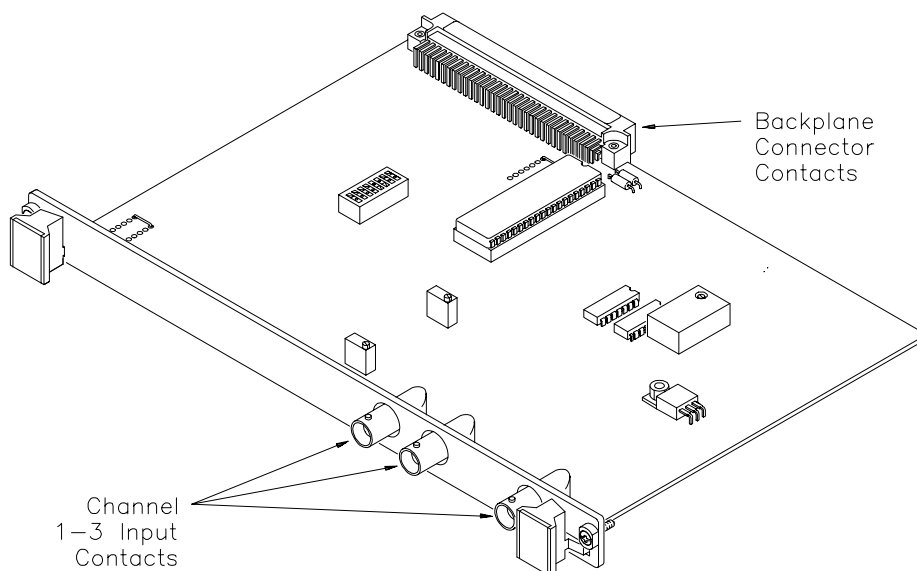

Figure 3-1. Cleaning the HP E133A Counter

Operator's Check

The Operator's Check for the HP E1333A counter consists of sending the self-test (*TST?) command and checking the return. The operator's check can be used at any time to verify the counter is connected properly and is responding to the self-test command. See Chapter 8, "Service," for a list of counter self-test errors.

As required, see the mainframe user's manual for information on address selection. See the *HP E1333A User's Manual* for information on counter SCPI commands.

Self-Test Procedure

1. Verify the counter is properly installed in the mainframe and the mainframe has passed its power-on sequence test.
2. Execute the counter self-test using the *TST? command (see example following).
3. A "0" returned means no self-test failure, while "1" through "7" returned means a failure was detected. See Chapter 8, "Service," for troubleshooting information (see NOTE below).

NOTE

Test failures can be caused by improper cabling, improper selection of the interface select code, primary, and/or secondary address setting. Verify proper connection and address selection before troubleshooting.

Example: Counter Self-Test

An example follows which uses an HP 9000 Series 300 computer with HP BASIC and a counter address of 70906.

```
10 OUTPUT 70906;"*TST?"           !Send the self-test command
20 ENTER 70906;A                   !Enter self-test result
30 PRINT A
40 END
```

Introduction

The three levels of test procedures described in this chapter are used to verify that the HP E1333A counter:

- is fully functional (Functional Verification)
- meets selected testable specifications (Operation Verification)
- meets all testable specifications (Performance Verification)

WARNING

Do not perform any of the following verification tests unless you are a qualified service trained person and have read the WARNINGS and CAUTIONS In Chapter 1.

Test Conditions and Procedures

For valid tests, all test equipment and the counter must have a one hour warm-up, and the line voltage must be 115/230 Vac \pm 10%. See Table 1-2, "Recommended Test Equipment," for test equipment requirements.

For best test accuracy, the ambient temperature of the test area should be between 18°C and 28°C and stable to within \pm 1°C. You should perform the Performance Verification tests at least once a year. For heavy use or severe operating environments, perform the tests more often.

The verification tests assume the person performing the tests understands how to operate the mainframe, counter and specified test equipment. The test procedures do not specify equipment settings for test equipment, except in general terms. It is assumed a qualified, service-trained person will select and connect the cables and adapters required for the tests.

Performance Test Record

Table 4-8, "Performance Test Record for the HP E1333A Counter," at the end of this chapter provides space to enter the results of each Performance Verification test and allows you to compare the results with the upper and lower limits for the test. You may make a copy of this form, if desired.

NOTE

The Performance Verification tests assume the test equipment used is calibrated and is operating at peak performance. If this is not the case, problems can occur.

For example, an uncalibrated source may cause what seems to be an inaccurate measurement. This condition must be considered when observed measurements do not agree with the performance test limits.

The value in the "Measurement Uncertainty" column of Table 4-8 is derived from the specifications for the source used for the test, and represents the expected accuracy of the source. The values in Table 4-8 assume the source is externally locked to a "house standard" with accuracy = $\pm (3 \times 10^{-11}) \times$ measurement, so the measurement uncertainty is that of the house standard.

The value in the Test Accuracy Ratio (TAR) column of Table 4-8 is the ratio of counter accuracy to measurement uncertainty, rounded to the nearest integer for TARs <10:1, or shown as ">10:1" for TARs >10:1. For example, if counter accuracy = $\pm 6.0 \times 10^{-6}$ Hz and measurement uncertainty = $\pm 3.0 \times 10^{-7}$ Hz, $TAR = \pm (6.0 \times 10^{-6} / 3.0 \times 10^{-7}) = \pm 20:1$. Since this is >10:1, the entry in Table 4-8 is ">10:1".

Verification Test Examples

Each performance verification test includes an example program to perform the test. Each example uses address 70906 for the counter, and an HP 9000 Series 200/300 computer running HP BASIC and SCPI (Standard Commands for Programmable Instruments) commands. You may need to change the counter address and/or command syntax to perform the examples for your setup.

As required, see the mainframe user's manual for information on address selection and cabling guidelines. See the *HP E1333A User's Manual* for information on counter SCPI commands.

Functional Verification Tests

The functional verification tests for the HP E1333A can be performed at any time to verify the counter is functional and is communicating with the mainframe, external computer and/or external terminal. The functional tests for the HP E1333A counter are:

- Counter Self-Test
- Totalizing Measurements Test (Optional)
- Ratio Measurements Test (Optional)
- Trigger Level Test (Optional)

Counter Self-Test

This test verifies the counter is communicating with the mainframe, external controller, and/or external terminal by performing a counter self-test (*TST? command). See "Operator's Checks" in Chapter 3 for a description of the counter self-test.

Totalizing Measurement Test

This test verifies the totalize measurement functions on Channels 1 and 2 at 1 Hz and 4 MHz. The test passes if the count increments on each channel. The test fails if the count remains at 0 for either or both channels.

Equipment Setup

Connect an HP 3325A function generator to Channel 1 and Channel 2 as shown in Figure 4-1. Then, set the HP 3325A output to 1 Hz sine wave at 50 mV rms.

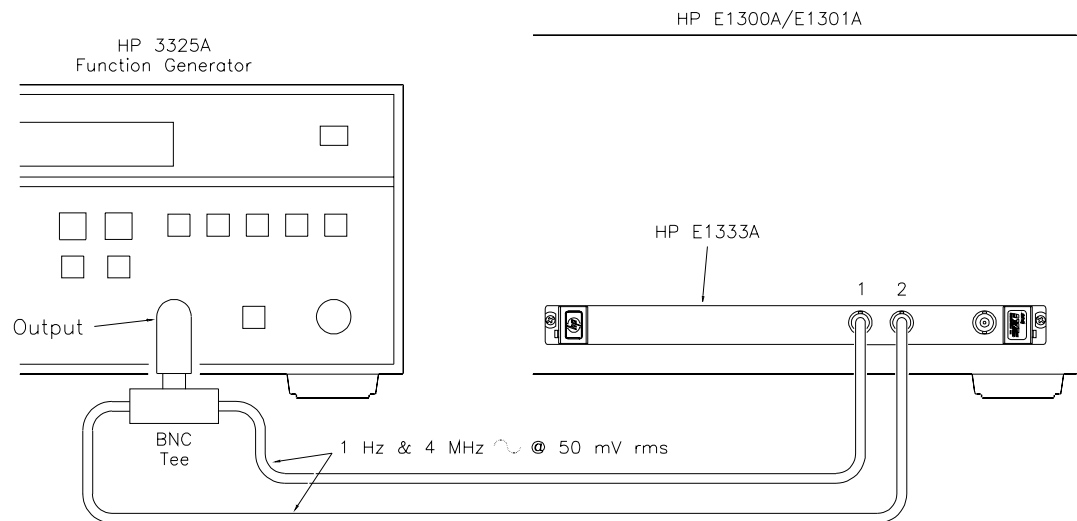

Figure 4-1. Totalizing Measurements Test Connections

Test Procedure

1. Set HP E1333A input conditions
 - Reset counter *RST
 - Set DC coupling..... INP:COUP DC
 - Set 50 Ω input impedance INP:IMP MIN
2. Totalize counts for 1 Hz input
 - Channel 1 to TOTAlize CONF1:TOT
 - Channel 2 to TOTAlize..... CONF2:TOT
 - Initiate measurement on Ch 1 INIT1
 - Return Ch 1 results..... FETC1?
 - Initiate measurement on Ch 2 INIT2
 - Return Ch 2 results..... FETC2?
 - Verify count increments on both channels
3. Totalize count for 4 MHz input
 - After 10-15 counts, set source to 4 MHz output
 - Repeat Step 2 for 4 MHz output
4. Remove power and disconnect test equipment

Example: Totalizing Measurements Functional Test

```
10 PRINT "Totalize counts for the following inputs:"
20 PRINT
30 PRINT "1 Hz, 50 mV rms sinewave"
40 PRINT "4 MHz, 50 mV rms sinewave"
50 DISP " Press any key to stop the program"
60 ON KBD GOTO Quit
70 OUTPUT 70906;"*RST"
80 OUTPUT 70906;"INP:COUP DC"
90 OUTPUT 70906;"INP:IMP MIN"
100 FOR Chan= 1 TO 2
110 OUTPUT 70906;"CONF"&VAL$(Chan)&":TOT"
120 OUTPUT 70906;"INIT"&VAL$(Chan)
130 NEXT Chan
140 Start: !
150 FOR Chan = 1 TO 2
160 OUTPUT 70906;"FETC"&VAL$(Chan)&"?"
170 ENTER 70906;Reading(Chan)
180 PRINT TABXY(1,7+Chan);"Channel ";Chan;" total counts =
";Reading(Chan)
190 NEXT Chan
200 GOTO Start
210 Quit: !
220 CLEAR SCREEN
230 END
```

Ratio Measurements Test

This test checks the ratio measurements function of the HP E1333A for Channel 1/Channel 2, using Channel 1 and Channel 2 frequencies and ratios shown in Table 4-1.

Table 4-1. Ch 1/Ch 2 Ratio Measurements

Ch 1 Freq	Ch 2 Freq	Ch 1/Ch 2 Ratio
1 MHz	100 Hz	10000
1 MHz	1 kHz	1000
1 MHz	10 kHz	100
1 MHz	100 kHz	10
1 MHz	1 MHz	1

Equipment Setup

Connect the equipment as shown in Figure 4-2. Then, set the Channel 1 and Channel 2 sources to output sine waves at 50 mV rms. Set Channel 1 frequency to 1 MHz

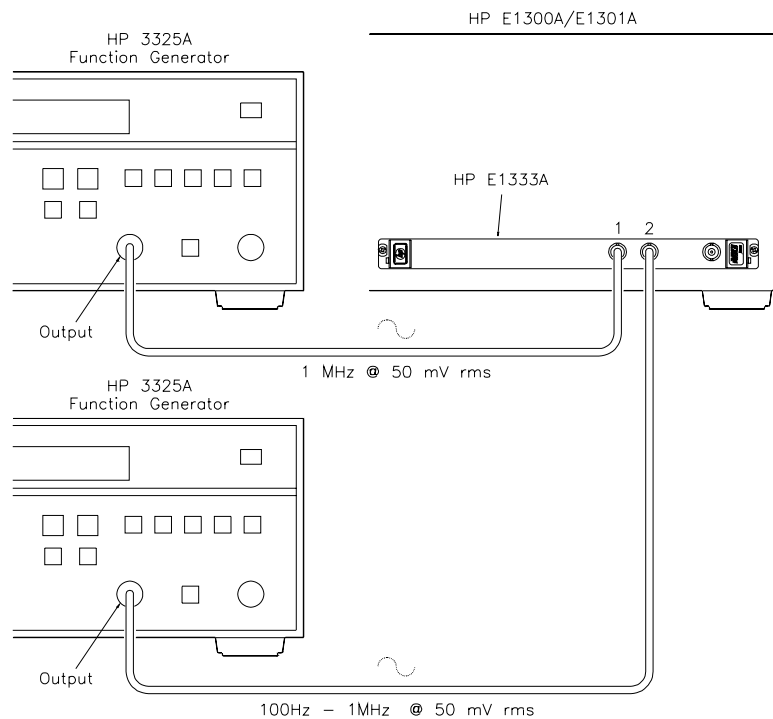

Figure 4-2. Ratio Measurements Test Connections

Test Procedure

1. Set the HP E1333A input conditions

- Reset Counter..... *RST
- Coupling to DC INP:COUP DC
- Input impedance to 50Ω..... INP:IMP MIN

2. Measure Ch 1/Ch 2 ratio at 100 Hz on Ch 2

- Set Ch 1 source output 1 MHz
- Set Ch 2 source output 100 Hz
- Set Ch 1 function, range, resolution . CONF1:RAT 1E6,1E3
- Initiate Ch 1/Ch 2 ratio meas INIT1
- Return Ch 1/Ch 2 ratio results FETC1?
- Verify returned result 10000

3. Repeat Step 2 for each Ch 2 frequency in Table 4-1.

4. Remove power and disconnect test equipment

**Example: Ratio
Measurements
Functional Test**

```
10 PRINT "Ch 1/Ch 2 ratio measurement"
20 PRINT
30 PRINT "Procedure:"
40 PRINT
50 PRINT " 1. Set Ch 1 source to 50 mV rms sine wave at 1 MHz "
60 PRINT " 2. Set Ch 2 source to 50 mV rms sine wave."
70 PRINT " 3. Vary Ch 2 freq from 100 Hz to 1 MHz (5 steps). "
80 PRINT " 4. Check Ch 1/Ch 2 ratio at each frequency step."
90 DISP " Press any key to stop the program "
100 ON KBD GOTO Quit
110 OUTPUT 70906;"*RST"
120 OUTPUT 70906;"INP:COUP DC"
130 OUTPUT 70906;"INP:IMP MIN"
140 Start: !
150 OUTPUT 70906;"CONF1:RAT 1E6,1E3"
160 OUTPUT 70906;"INIT1"
170 WAIT 1
180 OUTPUT 70906;"FETC1?"
190 ENTER 70906;Rdg
200 OUTPUT 70906;"MEAS2:FREQ?"
210 ENTER 70906;Ch2_freq
220 Ch2_freq = PROUND(Ch2_freq,2)
230 PRINT TABXY(1,12);"Results:"
240 PRINT TABXY(5,14);"Ch 2 frequency = ";Ch2_freq;"Hz      "
250 PRINT TABXY(5,15);"Ch 1/Ch 2 ratio = ";Rdg;"      "
260 GOTO Start
270 Quit: !
280 CLEAR SCREEN
290 END
```

Trigger Level Test

This test checks the trigger level accuracy on Channel 1 for the -2.56V, 0V, +2.54V and +25.4V trigger levels. Table 4-2 shows the trigger levels measured, the input attenuation level in dB, and the below-level and above-level voltage values for each trigger level.

Table 4-2. Trigger Level Tests

Trigger Level (V)	Input Attenuation (dB)	Below-Level Value (V)	Above-Level Value (V)
-2.56	0	-2.836	-2.284
+0.00	0	-0.02	+0.02
+2.54	0	+2.266	+2.814
+25.4	20	+22.66	+28.14

For this test, the HP E1333A is set to TOTAlize mode and the desired trigger level is set. Next, a DC voltage is input which is less than the specified trigger level value and the count is measured (should be 0). The voltage is then set above the trigger level value and the totalized count is measured again (should be at least 1). If the increased count is >0, the test passes. The below-level and above-level values in Table 4-2 are derived from:

$$\begin{aligned} \text{Below-Level Value (0 dB)} &= \text{Trig Lvl} - |.02 + |\text{Trig Lvl}/10|| \\ \text{Above-Level Value (0 dB)} &= \text{Trig Lvl} + |.02 + |\text{Trig Lvl}/10|| \\ \text{Below-Level Value (20 dB)} &= \text{Trig Lvl} - |.20 + |\text{Trig Lvl}/10|| \\ \text{Above-Level Value (20 dB)} &= \text{Trig Lvl} + |.20 + |\text{Trig Lvl}/10|| \end{aligned}$$

Equipment Setup

Connect the equipment as shown in Figure 4-3. Then, set the DC Standard for DC output.

Test Procedure

1. Set HP E1333A input conditions
 - Reset Counter *RST
 - Coupling to DC INP:COUP DC
 - Input filter to ON INP:FILT ON

2. Test Low-Level Trigger Levels (Below-Level Value Setting)
 - Set the DC Standard output -2.836 Vdc
 - Channel 1 to TOTAlize SENS1:FUNC:TOT
 - Ch 1 trig lvl to -2.56V SENS1:EVENT:LEV -2.56
 - Initiate Ch 1 measurement INIT1
 - Return Ch 1 results FETC1?
 - Verify returned result 0 counts

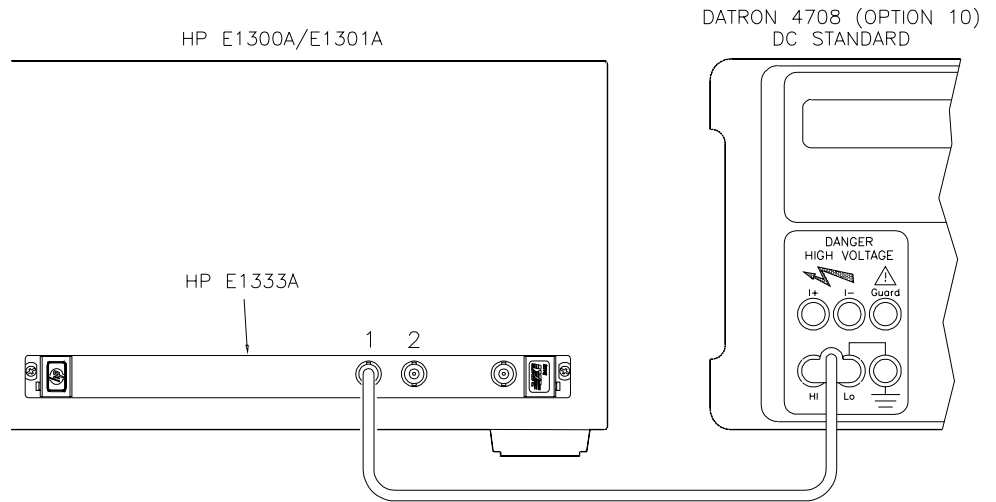

Figure 4-3. Trigger Level Tests Connections

3. Test Low-Level Trigger Levels (Above-Level Value Setting)

- Set DC Standard output -2.284 Vdc
- Initiate Ch 1 measurement INIT1
- Return Ch 1 results FETC1?
- Verify returned result at least 1 count

4. Repeat Steps 2 and 3 for the 0 V and +2.54 V trigger levels, using the Below-Level and Above-Level Values in Table 4-2.

5. Test High-Level Trigger Level

NOTE

When the input attenuation is 20 dB, you must divide the desired trigger level by 10, and then enter the result using SENS:EVENT:LEV value.

- Set 20 dB input atten INP:ATT MAX
- Set DC Standard output +22.66 Vdc
- Ch 1 trig lvl to +25.4V SENS1:EVENT:LEV 2.54
- Initiate Ch 1 measurement INIT1
- Return Ch 1 results FETC1?
- Verify returned result 0 counts

- Set DC Standard output +28.14 Vdc
- Initiate Ch 1 measurement INIT1
- Return Ch 1 results FETC1?
- Verify returned result at least 1 count

6. Remove power and disconnect test equipment

Example: Trigger Level Functional Test

```
10  OPTION BASE 1
20  DIM Trig_lev(4),Low(4),High(4),Lvl(4)
30  DATA -2.56,0,2.54,25.4
40  DATA -2.836,-.02,2.266,22.66
50  DATA -2.284,.02,2.814,28.14
60  READ Trig_lev(*)
70  READ Low(*)
80  READ High(*)
90  !
100 OUTPUT 70906;"*RST"
110 OUTPUT 70906;"INP:COUP DC"
120 OUTPUT 70906;"INP:FILT ON"
130 OUTPUT 70906;"CONF1:TOT"
140 FOR I = 1 TO 4
150 IF I = 4 THEN
160     OUTPUT 70906;"1NP:ATT MAX"
170     Lvl(I) = Trig_lev(I)/10
180 ELSE
190     OUTPUT 70906;"INP:ATT MIN"
200     Lvl(I) = Trig_Lvl(I)
210 END IF
220 OUTPUT 70906;"SENS1:EVEN:LEV";Lvl(I)
230 PRINT TABXY(1,1);"Trigger level= ";Trig_lev(I);"V"
240 PRINT TABXY(1,4);"Procedure:"
250 !
260 PRINT TABXY(5,6);"1. Set source to ";Low(I);"Volts.  "
270 PRINT TABXY(5,7);"2. Increase source to ";High(I);"Volts.  "
280 PRINT TABXY(5,8);"3. Verify that Channel 1 count increases."
290 OUTPUT 70906;"INIT1"
300 DISP "For next trigger level, press any key."
310 ON KBD GOTO Next_lvl
320 Start: !
330 OUTPUT 70906;"FETC1?"
340 ENTER 70906;Reading
350 PRINT TABXY(10,12);"Channel 1 count = ";Reading;"    "
360 GOTO Start
370 Next_lvl: !
380 NEXT I
390 OUTPUT 70906;"INP:ATT MIN"
400 DISP "Test completed."
410 STOP
420 END
```

Operation Verification Tests

Operation verification test objectives are to instill a high degree of confidence that the HP E1333A 3-Channel Universal Counter is meeting selected specifications from those listed in Appendix A, "Specifications," in the *HP E1333A User's manual*.

Operation verification tests can be used in applications such as incoming inspection and after HP E1333A repair. To perform operation verification tests, do the parts of the performance verification tests shown in Table 4-3.

NOTE

For best results, the HP E1333A 10 MHz reference oscillator should be adjusted to 10 MHz \pm 10Hz. Before using the operation verification tests, you may want to perform the Reference Oscillator Adjustment procedure in Chapter 5, "Adjustments."

Table 4-3. Operation Verification Tests

Test	Test These Specifications
Frequency	Chan 1: 1 kHz, 8.192 sec gate Chan 1: 1 MHz, 1.024 sec gate Chan 2: 100 MHz, 0.002 sec gate Chan 3: 400 MHz, 0.016 sec gate
Period average	Chan 1: 1 msec period, average 16 periods Chan 1: 1 μ sec period, average 1024 periods
Pulse Width	Chan 1: 1 msec pulse width, POS pulse Chan 2: 1 msec pulse width, POS pulse
Time Interval	Chan 1: 500 nsec interval, Ch 1 POS to Ch 2 NEG edge Chan 2: 500 nsec Interval, Ch 2 POS to Ch 1 NEG edge

Performance Verification Tests

Performance verification test objectives are to instill a high degree of confidence that the HP E1333A 3-Channel Universal Counter is meeting the specifications listed in Appendix A, "Specifications," of the *HP E1333A User's Manual*. Performance verification tests are required whenever a calibration is required. The HP E1333A counter performance verification tests are:

- Frequency Measurements
- Period Average Measurements
- Pulse Width Measurements
- Time Interval Measurements

NOTE

For best results, the HP E1333A 10 MHz reference oscillator should be adjusted to 10 MHz \pm 10 Hz. Before beginning the performance verification tests, you may want to perform the Reference Oscillator Adjustment procedure in Chapter 5 - "Adjustments."

Frequency Measurements Test

This test checks frequency measurement accuracy on Channels 1, 2, and 3. Input level sensitivity is tested indirectly by using input signals with amplitudes equal to the sensitivity limits.

Table 4-4. Frequency Measurements Performance Tests

Ch	Source	Source Ampl (mV rms)	Source Freq	Aperture Time (sec)
1	HP 3325A	25 mV rms	10 Hz	32.768
			100 Hz	16.384
			1 kHz	8.192
			10 kHz	4.096
			100 kHz	2.048
			1 MHz	1.024
			4 MHz	.512
			10 MHz	.256
1	HP 8663A	25 mV rms	20 MHz	.128
			50 MHz	.064
			100 MHz	.032
			100 MHz	.016
			100 MHz	.008
			100 MHz	.004
			100 MHz	.002
			100 MHz	65.536
2	HP 8663A	25 mV rms	100 MHz	.002
3	HP 8663A	10 mV	75 MHz	.128
		10 mV	100 MHz	.064
		10 mV	200 MHz	.032
		10 mV	400 MHz	.016
		10 mV	600 MHz	.008
		30 mV	900 MHz	.004
		40 mV	1 GHz	.002

Equipment Setup

Connect the equipment as shown in Figure 4-4. For measurements from 10 Hz through 10 MHz, connect the HP 3325A Function Generator to Channel 1. For measurements above 10 MHz, connect the HP 8663A Signal Generator to Channel 1, 2 or 3. Set outputs for sine wave.

NOTE

If a frequency test fails, measure the ACTUAL input to the HP E1333A to ensure that the input is the appropriate value (25 mV, 10 mV, 30 mV, or 40 mV rms). If the input is less than the specified value, increase the source output as required.

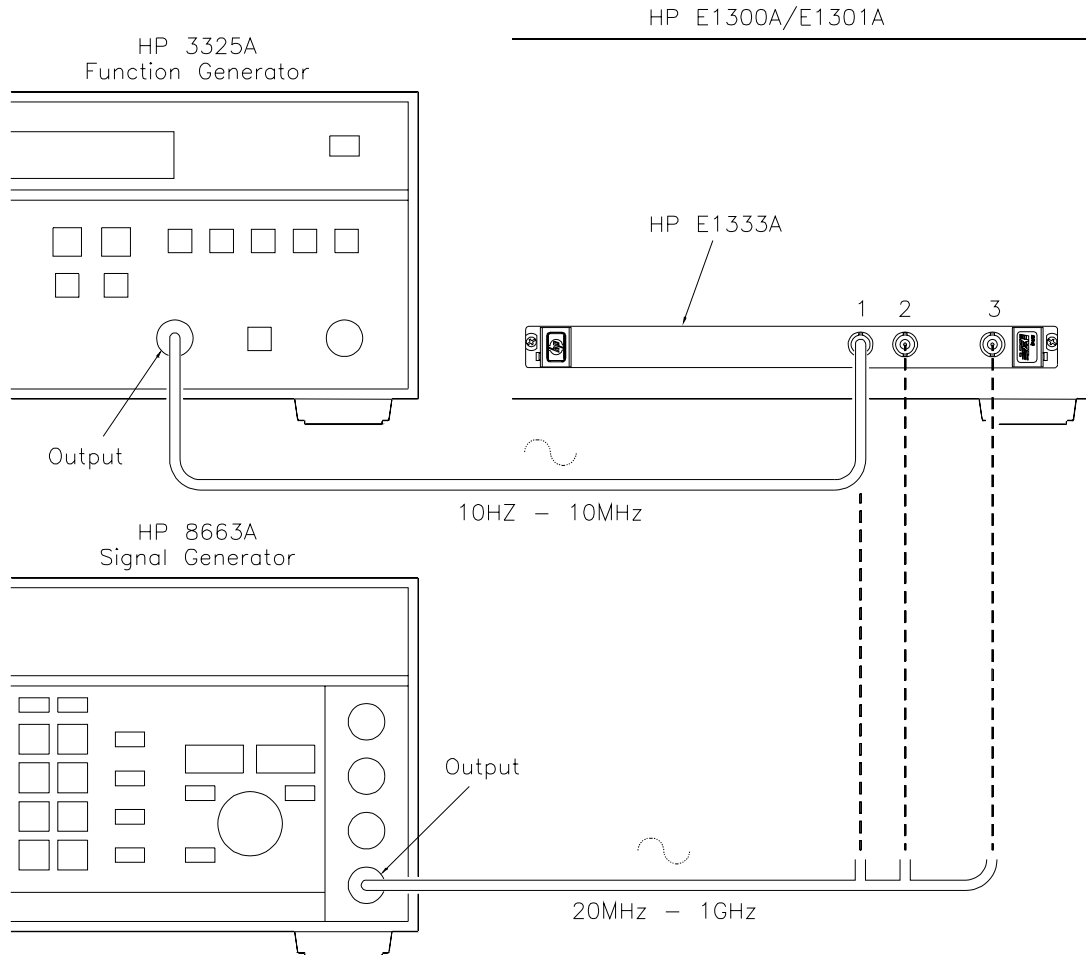

Figure 4-4. Frequency Measurements Test Connections

Test Procedure

1. Set HP E1333A input conditions:

- Reset counter *RST
- Set DC coupling INP:COUP DC
- Set 50 Ω input impedance INP:IMP MIN

2. Measure Channel 1 frequencies (HP 3325A Source)

- Connect HP 3325A to Channel 1
- Set HP 3325A output 10 Hz at 25 mV rms
- Set FREQ function on Ch 1 SENS1:FUNC:FREQ
- Set 32.768 sec aperture SENS1:FREQ:APER 32.768
- Read measurement result READ1?
- Verify result within limits Table 4-8
- Repeat steps for each HP 3325A Channel 1 source frequency, source amplitude and aperture time entry in Table 4-4.

3. Measure Channel 1 frequencies (HP 8663A Source)

- Connect HP 8663A to Channel 1
- Set HP 8663A output 20 MHz at 25 mV rms
- Set .128 sec aperture SENS1:FREQ:APER .128
- Read measurement result READ1?
- Verify result within limits Table 4-8
- Repeat steps for each HP 8663A Channel 1 source frequency, source amplitude and aperture time entry in Table 4-4

4. Measure Channel 2 frequency (HP 8663A Source)

- Connect HP 8663A to Channel 2
- Set HP 8663A output 100 MHz at 25 mV rms
- Set .002 sec aperture SENS2:FREQ:APER .002
- Read measurement result READ2?
- Verify result within limits Table 4-8

5. Measure Channel 3 frequencies (HP 8663A Source)

- Connect HP 8663A to Channel 3
- Set HP 8663A output 75 MHz at 10 mV rms
- Set .128 sec aperture SENS3:FREQ:APER .128
- Read measurement result READ3?
- Verify result within limits Table 4-8
- Repeat steps for each HP 8663A Channel 3 source frequency, source amplitude and aperture time entry in Table 4-4

6. Remove power and disconnect test equipment

Example: Frequency Measurements Test

This program measures frequency on Channels 1, 2, and 3 for the frequencies and aperture times shown in Table 4-4.

NOTE

Some measurements take up to 65 seconds to complete. If a measurement appears to take too long, check connections and/or code you entered.

```
10 OPTION BASE 1
20 DIM Aper(24),Ampl$(24)[10],Freq(24),Freq$(24)[10], Chan(24),Read(24)
30 DATA 32.768, 16.384, 8.192, 4.096, 2.048, 1.024, .512, .256
40 DATA .128, .064, .032, .016, .008, .004, .002, 65.536
50 DATA .002, .128, .064, .032, .016, .008, .004, .002
60 READ Aper(*)
70 DATA 25 mV, 25 mV, 25 mV, 25 mV, 25 mV, 25 mV, 25 mV, 25 mV
80 DATA 25 mV, 25 mV, 25 mV, 25 mV, 25 mV, 25 mV, 25 mV, 25 mV
90 DATA 25 mV, 10 mV, 10 mV, 10 mV, 10 mV, 10 mV, 30 mV, 40 mV
100 READ Ampl$(*)
110 DATA 1.E1,1.E2,1.E3,1.E4,1.E5,1.E6,4.E6,1.E7
120 DATA 2.E7,5.E7,1.E8,1.E8,1.E8,1.E8,1.E8,1.E8
130 DATA 1.E8,7.5E7,1.E8,2.E8,4.E8,6.E8,9.E8,1.E9
140 READ Freq(*)
150 DATA 10 Hz, 100 Hz, 1 kHz, 10 kHz, 100 kHz, 1 MHz, 4 MHz, 10 MHz
160 DATA 20 MHz, 50 MHz, 100 MHz, 100 MHz, 100 MHz, 100 MHz, 100
MHz, 100 MHz
170 DATA 100 MHz, 75 MHz, 100 MHz, 200 MHz, 400 MHz, 600 MHz, 900
MHz, 1 GHz
180 READ Freq$(*)
190 OUTPUT 70906;"*RST"
200 OUTPUT 70906;"INP:COUP DC"
210 OUTPUT 70906;"INP:IMP MIN"
220 FOR I = 1 TO 24
230 IF I < 17 THEN Chan(I) = 1
240 IF I = 17 THEN Chan(I) = 2
250 IF I > 17 THEN Chan(I) = 3
260 OUTPUT CRT;"Frequency Measurements on Channel";Chan(I)
270 OUTPUT CRT;"Frequency = ";Freq$(I)
280 OUTPUT CRT;"Aperture time = ";Aper(I);" sec"
290 OUTPUT CRT;" "
300 OUTPUT CRT;" Set source frequency to ";Freq$(I)
310 OUTPUT CRT;" Set source output to ";Ampl$(I);" rms"
320 DISP " Press Continue when ready "
330 PAUSE
340 CLEAR SCREEN
350 OUTPUT 70906;"SENS"&VAL$(Chan(I))&":FUNC:FREQ"
360 OUTPUT 70906;"SENS"&VAL$(Chan(I))&":FREQ:APER ";Aper(I)
370 OUTPUT 70906;"READ"&VAL$(Chan(I))&":?"
380 ENTER 70906;Read(I)
390 NEXT I
400 PRINT "Frequency Measurements Performance Test Completed."
410 PRINT "Press Continue to display the results."
420 PAUSE
430 CLEAR SCREEN
440 PRINT " HP E1333A counter Frequency Measurements"
450 PRINT
460 Format:IMAGE 4X,2A,4X,9A,5X,9A,8X,9A
470 PRINT USING Format;"Ch";"Frequency";"Aper Time";"Measured"
480 PRINT USING Format;" ";"(Hz)";"(sec)";"Freq (Hz)"
490 PRINT
500 Format1:1IMAGE 4X,D,5X,7A,6X,2D.3D,7X,10D.3D
510 FOR I = 1 TO 24
520 PRINT USING Format1;Chan(I);Freq$(I);Aper(I);Read(I)
530 NEXT I
540 END
```

A typical return is:

HP E1333A Counter Frequency Measurements

Ch	Frequency (Hz)	Aper Time (sec)	Measured Freq (HZ)
1	10 Hz	32.768	9.979
1	100 Hz	16.384	99.976
1	1 kHz	8.192	999.878
	.		
	.		
	.		
3	1 GHz	0.002	1000003001.000

Period Average Measurements Test

This test measures period averages on Channel 1 only. Period average measurements are made with the frequencies, periods and number of periods averaged shown in Table 4-5. (Channel 2 is not tested since the same circuitry is used for Channels 1 and 2.)

Table 4-5. Period Measurements Performance Tests

Chan	Source Frequency	Source Period	Periods Averaged
1	1 Hz	1 sec	2
	10 Hz	100 msec	4
	100 Hz	10 msec	8
	1 kHz	1 msec	16
	5 kHz	200 usec	32
	10 kHz	100 usec	64
	50 kHz	20 usec	128
	100 kHz	10 usec	256
	500 kHz	2 usec	512
	1 MHz	1 usec	1024
	2 MHz	500 nsec	2048
	5 MHz	200 nsec	4096
	10 MHz	100 nsec	8192

Equipment Setup

Connect an HP 3325A Function Generator to Channel 1 as shown in Figure 4-5. Then, set HP 3325A to output sine waves at 50 mV rms.

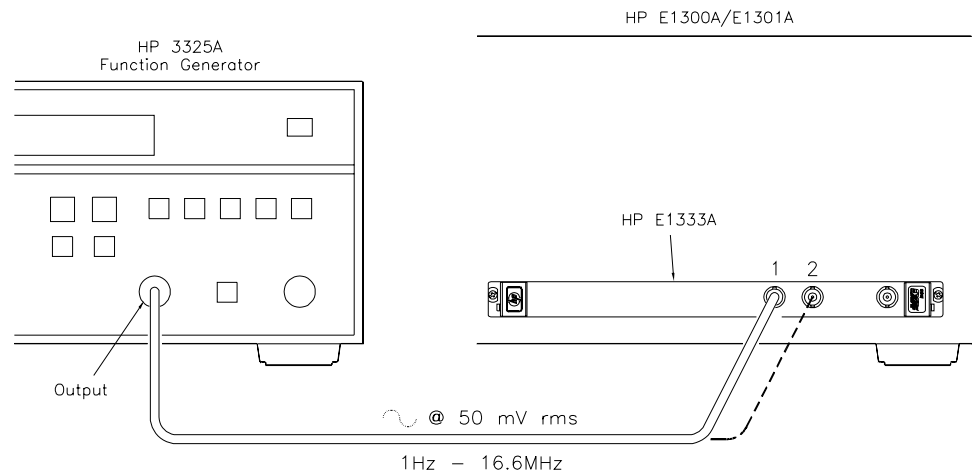

Figure 4-5. Period Measurements Test Connections

Test Procedure

1. Set HP E1333A Input conditions

- Reset counter *RST
- Set DC coupling INP:COUP DC
- Set 50 Ω Input Impedance INP:IMP MIN

2. Measure Channel 1 periods

- Connect HP 3325A to Channel 1
- Set HP 3325A output 1 Hz at 50 mV rms
- Set PER function on Ch 1 SENS1:FUNC:PER
- Set 2 periods avgd SENS1:PER:NPER 2
- Read measurement result READ1?
- Verify result within limits Table 4-8
- Repeat steps for each HP 3325A Channel 1 source frequency and periods averaged entry in Table 4-5.

3. Remove power and disconnect test equipment

Example: Period Average Measurements

This program measures period averages on Channel 1 for the periods and number of periods averaged shown in Table 4-5.

```
10 OPTION BASE 1
20 DIM Nper(13),Per$(13)[10],Freq$(13)[10],Read(13)
30 DATA 2,4,8,16,32,64,128,256,512
40 DATA 1024,2048,4096,8192
50 READ Nper(*)
60 DATA 1 sec, 100 msec, 10 msec, 1 msec, 200 usec, 100 usec, 20 usec
70 DATA 10 usec, 2 usec, 1 usec, 500 nsec, 200 nsec, 100 nsec
80 READ Per$(*)
90 DATA 1 Hz, 10 Hz, 100 Hz, 1 kHz, 5 kHz, 10 kHz, 50 kHz
100 DATA 100 kHz, 500 kHz, 1 MHz, 2 MHz, 5 MHz, 10 MHz
110 READ Freq$(*)
120 OUTPUT 70906;"*RST"
130 OUTPUT 70906;"INP:COUP DC"
140 OUTPUT 70906;"INP:IMP MIN"
150 FOR I = 1 TO 13
160 OUTPUT CRT;"Period Average Measurements on Channel 1"
170 OUTPUT CRT;"Period = ";Per$(I)
180 OUTPUT CRT;"Periods averaged = ";Nper(I)
190 OUTPUT CRT;" "
200 OUTPUT CRT;" Set source frequency to ";Freq$(I);" sine wave"
210 OUTPUT CRT;" Set source output to 50 mV rms"
220 DISP " Press Continue when ready "
230 PAUSE
240 CLEAR SCREEN
250 OUTPUT 70906;"SENS1:FUNC:PER"
260 OUTPUT 70906;"SENS1:PER:NPER ";Nper(I)
270 OUTPUT 70906;"READ1?"
280 ENTER 70906;Read(I)
290 NEXT I
300 PRINT "Period Measurements Performance Test Completed."
310 PRINT "Press Continue to display the results."
320 PAUSE
330 CLEAR SCREEN
340 PRINT " HP E1333A Counter Period Measurements"
350 PRINT
```

(Continued on Next Page)

```

360 Format:IMAGE 4X,2A,4X,9A,5X,9A,4X,13A
370 PRINT USING Format;"Ch";"Period";"Periods";"Measured"
380 PRINT USING Format;" ";"(sec)";"Averaged";"Period (sec)"
390 PRINT
400 Format1:IMAGE 4X,A,5X,8A,6X,5D,7X,D.7DE
410 FOR I = 1 TO 13
420 PRINT USING Format1;"1";Per$(I);Nper(I);Read(I)
430 NEXT I
440 END

```

A typical return is:

HP E1333A Counter Period Measurements

Ch	Period (sec)	Periods Averaged	Measured Period (sec)
1	1 sec	2	9.9999155E-01
1	100 msec	4	9.9999724E-02
1	10 msec	8	1.0000020E-02
	.		
	.		
	.		
1	100 nsec	8192	1.0000000E-07

Pulse Width Measurements Test

This test measures positive and negative pulse width averages on Channels 1 and 2 at 0.5 Hz and 500Hz. Table 4-6 shows the pulse widths and pulse polarities measured.

Table 4-6. Pulse Width Measurements Tests

Ch	Pulse Width	Pulse Polarity
1	1 sec	POS
	1 sec	NEG
	1 msec	POS
	1 msec	NEG
2	1 sec	POS
	1 sec	NEG
	1 msec	POS
	1 msec	NEG

Equipment Setup

Connect the HP 3325A Function Generator to Channel 1 as shown in Figure 4-6. Then, set the HP 3325A to output a square wave at 50 mV rms.

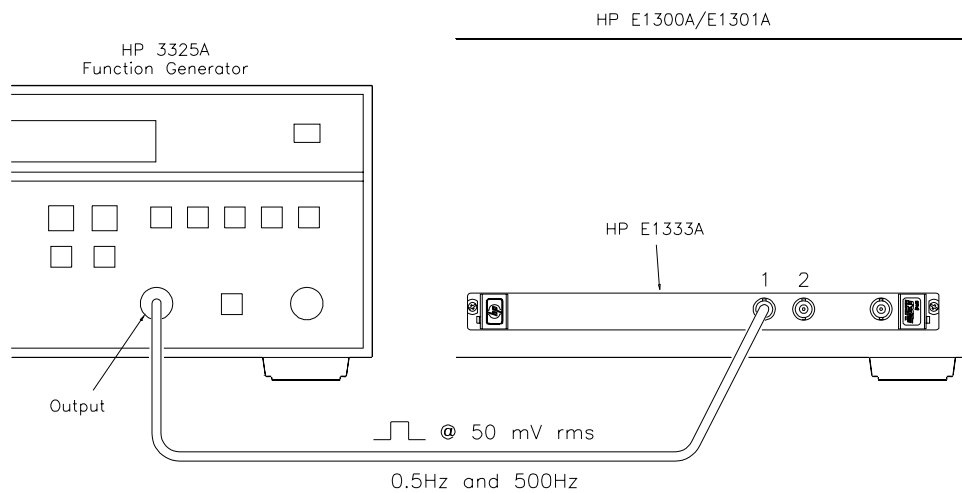

Figure 4-6. Pulse Width Measurements Connections

Test Procedure

1. Set HP E1333A input conditions

- Reset counter *RST
- Set DC coupling INP:COUP DC
- Set 50 Ω input impedance INP:IMP MIN

2. Measure Channel 1 positive pulse widths

- Connect HP 3325A to Channel 1
- Set HP 3325A output 0.5 Hz
- Set pos pulse width on Ch 1 SENS1:FUNC:PWID
- Average 2 periods SENS1:TINT:NPER 2
- Read measurement result READ1?
- Verify result within limits Table 4-8
- Repeat steps for 500 Hz

3. Measure Channel 1 negative pulse widths

- Set HP 3325A output 0.5Hz
- Set neg pulse width on Ch 1 SENS1:FUNC:NWID
- Read measurement result READ1?
- Verify result within limits Table 4-8
- Repeat steps for 500 Hz

4. Measure Channel 2 positive pulse widths

- Connect HP 3325A to Channel 2
- Set HP 3325A output 0.5 Hz
- Set pos pulse width on Ch 2 SENS2:FUNC:PWID
- Average 2 periods SENS2:TINT:NPER 2
- Read measurement result READ2?
- Verify result within limits Table 4-8
- Repeat steps for 500 Hz

5. Measure Channel 2 negative pulse widths

- Set HP 3325A output 0.5 Hz
- Set neg pulse width on Ch 2 SENS2:FUNC:NWID
- Read measurement result READ2?
- Verify result within limits Table 4-8
- Repeat steps for 500 Hz

6. Remove power and disconnect test equipment

Example: Pulse Width Measurements

This program measures positive and negative pulse widths on Channels 1 and 2 for 0.5 Hz and 500 Hz

```
10 OPTION BASE 1
20 DIM Freq$(8)[10],Read(8),Pulse(8),Pol$(8)[10],Chan(8),Pulse$(8)[10],
Type$(8)[10]
30 DATA 1.,.001,1.,.001,1.,.001,1.,.001
40 READ Pulse(*)
50 DATA 1 sec, 1 sec, 1 msec, 1 msec
60 DATA 1 sec, 1 sec, 1 msec, 1 msec
70 READ Pulse$(*)
80 DATA POS,NEG,POS,NEG,POS,NEG,POS,NEG
90 READ Type$(*)
100 DATA PWID,NWID,PWID,NWID,PWID,NWID,PWID,NWID
110 READ Pol$(*)
120 DATA 0.5 Hz, 0.5 Hz, 500 Hz, 500 Hz
130 DATA 0.5 Hz, 0.5 Hz, 500 Hz, 500 Hz
140 READ Freq$(*)
150 OUTPUT 70906;"*RST"
160 OUTPUT 70906;"INP:COUP DC"
170 OUTPUT 70906;"INP:IMP MIN"
180 FOR I = 1 TO 8
190 IF I <= 4 THEN Chan(I) = 1
200 IF I > 4 THEN Chan(I) = 2
210 OUTPUT CRT;"Pulse Width Measurements on Channel";Chan(I)
220 OUTPUT CRT;""
230 OUTPUT CRT;"Measure ";Type$(I);" Pulse Width"
240 OUTPUT CRT;"Pulse Width = ";Pulse$(I)
250 OUTPUT CRT;"Periods averaged = 2"
260 OUTPUT CRT;" "
270 OUTPUT CRT;" Set source frequency to ";Freq$(I);" square wave"
280 OUTPUT CRT;" Set source output to 50 mV rms"
290 DISP " Press Continue when ready "
300 PAUSE
310 CLEAR SCREEN
320 OUTPUT 70906;"SENS"&VAL$(Chan(I))&":FUNC:";Pol$(I)
330 OUTPUT 70906;"SENS"&VAL$(Chan(I))&":PER:NPER 2"
340 OUTPUT 70906;"READ"&VAL$(Chan(I))&"?"
350 ENTER 70906;Read(I)
360 NEXT I
370 PRINT "Pulse Width Measurements Performance Test Completed."
380 PRINT "Press Continue to display the results."
390 PAUSE
400 CLEAR SCREEN
410 PRINT " HP E1333A Counter Pulse Width Measurements"
420 PRINT
430 Format:IMAGE 4X,2A,4X,9A,4X,9A,5X,12A
440 PRINT USING Format;"Ch";"Pulse";"Pulse";"Measured"
450 PRINT USING Format;" ";"Width";"Polarity";"Width (msec)"
460 PRINT
470 Format1:IMAGE 4X,D,5X,8A,5X,8A,6X,4D,5D
480 FOR I = 1 TO 8
490 PRINT USING Format1;Chan(I);Pulse$(I);Type$(I);Read(I)*1000
500 NEXT I
510 END
```

A typical return is:

HP E1333A Counter Pulse Width Measurements

Ch	Pulse Width	Pulse Polarity	Measured Width (msec)
1	1 sec	POS	999.99706
1	1 sec	NEG	1000.00666
1	1 msec	POS	1.00006
1	1 msec	NEG	.99976
2	1 sec	POS	1000.02296
2	1 sec	NEG	1000.05296
2	1 msec	POS	1.00026
2	1 msec	NEG	.99966

Time Interval Measurements Test

This test checks time interval accuracy on Channels 1 and 2 for the time interval and edges shown in Table 4-7, where POS = rising edge and NEG = falling edge of channel input.

Table 4-7. Time Interval Measurements Tests

Ch	Time Interval	Ch 1 Edge	Ch 2 Edge
1	500 nsec	POS	NEG
2	500 nsec	NEG	POS

Equipment Setup

Connect the HP 3325A Function Generator to Channels 1 and 2 (tee connection) as shown in Figure 4-7. Then, set the HP 3325A to output 1 MHz square waves at 50 mV rms.

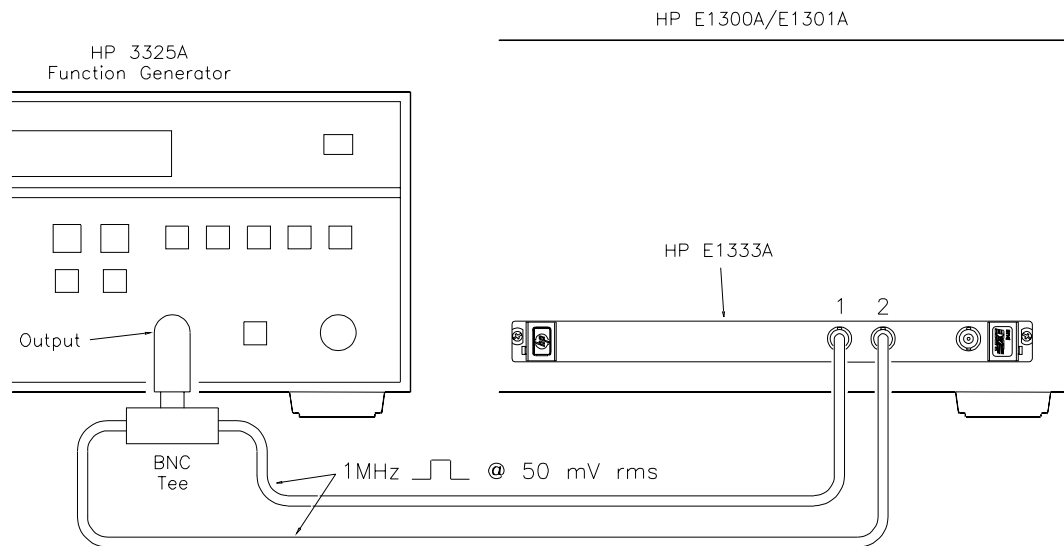

Figure 4-7. Time Interval Measurements Connections

Test Procedure

1. Set HP E1333A input conditions
 - Reset counter *RST
 - Set DC coupling INP:COUP DC
 - Set 50Ω input Impedance INP:IMP MIN
2. Measure Channel 1 time interval
 - Set time interval on Ch 1 SENS1:FUNC:TINT
 - Set Ch 1 POS edge SENS1:EVEN:SLOP POS
 - Set Ch 2 NEG edge SENS2:EVEN:SLOP NEG
 - Read measurement result READ1?
 - Verify result within limits Table 4-8
3. Measure Channel 2 time interval
 - Set time interval on Ch 2 SENS1:FUNC:TINT
 - Set Ch 1 NEG edge SENS1:EVEN:SLOP NEG
 - Set Ch 2 POS edge SENS2:EVEN:SLOP POS
 - Read measurement result READ2?
 - Verify result within limits Table 4-8
4. Remove power and disconnect test equipment.

Example: Time Interval Measurements

This program measures time intervals for a 1 MHz signal input to Channels 1 and 2.

```
10 OPTION BASE 1
20 DIM Chan(2),Read(2),Slope1$(2)[10],Slope2$(2)[10]
30 DATA 1,2
40 READ Chan(*)
50 DATA POS,NEG
60 READ Slope1$(*)
70 DATA NEG,POS
80 READ Slope2$(*)
90 OUTPUT 70906;"*RST"
100 OUTPUT 70906;"INP:COUP DC "
110 OUTPUT 70906;"INP:IMP MIN"
120 FOR I = 1 TO 2
130 OUTPUT CRT;"Time Interval Measurements on channel";Chan(I)
140 OUTPUT CRT;"From Channel 1 ";Slope1$(I);" edge to Channel 2 ";
Slope2$(I);" edge"
150 OUTPUT CRT;" "
160 OUTPUT CRT;" Set output to 1 MHz square wave @ 50 mV rms"
170 DISP " Press Continue when ready "
180 PAUSE
190 CLEAR SCREEN
200 IF I = 1 THEN Ch1_meas
210 IF I = 2 THEN Ch2_meas
220 Ch1_meas: !
230 OUTPUT 70906;"SENS1:FUNC:TINT"
240 OUTPUT 70906;"SENS1:EVEN:SLOP POS"
250 OUTPUT 70906;"SENS2:EVEN:SLOP NEG"
260 OUTPUT 70906;"READ1?"
270 ENTER 70906;Read(I)
280 GOTO Continue
290 Ch2_meas:
300 OUTPUT 70906;"SENS2:FUNC:TINT"
310 OUTPUT 70906;"SENS1:EVEN:SLOP NEG"
320 OUTPUT 70906;"SENS2:EVEN:SLOP POS"
330 OUTPUT 70906;"READ2?"
340 ENTER 70906;Read(I)
350 Continue: !
360 NEXT I
370 PRINT "Time Interval Measurement Performance Test Completed."
380 PRINT "Press Continue to display the results."
390 PAUSE
400 CLEAR SCREEN
410 PRINT " HP E1333A Counter Time Interval Measurements"
420 PRINT
430 Format:IMAGE 4X,2A,6X,10A,3X,5A,3X,5A,5X,9A
440 PRINT USING Format;"Ch";"Time";"Ch 1";"Ch 2";"Measured"
450 PRINT USING Format;" ";"Interval";"Edge";"Edge";"Interval"
460 PRINT USING Format;" ";"(nsec)";" ";"(nsec)"
470 PRINT
480 Format1:IMAGE 4X,D,8X,4A,8X,3A,5X,3A,5X,4D.3D
490 FOR I = 1 TO 2
500 PRINT USING Format1;Chan(I);"500";Slope1$(I);Slope2$(I); Read(I)*1.E
+9
510 NEXT I
520 END
```

A typical return is:

HP E1333A Counter Time Interval Measurements

Ch	Time Interval (nsec)	Ch 1 Edge	Ch2 Edge	Measured Interval (sec)
1	500	POS	NEG	456.348
2	500	NEG	NEG	556.931

Performance Test Record

Table 4-8, "Performance Test Record for the HP E1333A Counter," can be used to record the results of each Operation Verification and Performance Verification test for the HP E1333A counter (this record can be copied if desired). The record includes the upper and lower limits, the measurement uncertainty, and the Test Accuracy Ratio (TAR) for the test.

NOTE

The values for counter accuracy, measurement uncertainty and TAR in Table 4-8 assume the following conditions. If your test conditions differ from these conditions, you will need to compute the appropriate values.

- Input noise (e_n) = 1 mV rms
 - Slew rate = $0.5 \times \text{freq (V/sec)} = 0.5/\text{period (V/sec)}$
 - Timebase error = $6.0 \times 10^{-6} \times \text{measurement}$
 - Measurement uncertainty = $3 \times 10^{-11} \times \text{measurement}$
-

Table 4-8. Performance Test Record for the HP E1333A Counter (Page 1 of 4)

Test Facility:	
Name _____	Report No. _____
Address _____	Date _____
City/State _____	Customer _____
Phone _____	Tested by _____
Model _____	Ambient temperature _____ °C
Serial No. _____	Relative humidity _____ %
Options _____	Line frequency _____ Hz (nominal)
Firmware Rev. _____	
 Special Notes:	

Table 4-8. Performance Test Record for the HP E1333A Counter (Page 2 of 4)

Model _____	Report No. _____	Date _____
-------------	------------------	------------

Test Equipment Used: Description	Model No.	Trace No.	Cal Due Date
1. _____	_____	_____	_____
2. _____	_____	_____	_____
3. _____	_____	_____	_____
4. _____	_____	_____	_____
5. _____	_____	_____	_____
6. _____	_____	_____	_____
7. _____	_____	_____	_____
8. _____	_____	_____	_____
9. _____	_____	_____	_____
10. _____	_____	_____	_____
11. _____	_____	_____	_____
12. _____	_____	_____	_____
13. _____	_____	_____	_____
14. _____	_____	_____	_____
15. _____	_____	_____	_____
16. _____	_____	_____	_____
17. _____	_____	_____	_____
18. _____	_____	_____	_____
19. _____	_____	_____	_____
20. _____	_____	_____	_____

Table 4-8. Performance Test Record for the HP E1333A Counter (Page 3 of 4)

Model _____	Report No. _____	Date _____
-------------	------------------	------------

Source Freq	Aper Time (sec)	Low Limit (Hz)	Measured Frequency (Hz)	High Limit (Hz)	Measurement Uncertainty (Hz)	Test Acc Ratio
Channel 1						
10 Hz	32.768	9.969	_____	10.031	3.00000E-10	>10:1
100 Hz	16.384	99.94	_____	100.06	3.00000E-09	>10:1
1 kHz	8.192	999.87	_____	1000.13	3.00000E-08	>10:1
10kHz	4.096	9999.7	_____	10000.3	3.00000E-07	>10:1
100 kHz	2.048	99999	_____	100001	3.00000E-06	>10:1
1MHz	1.024	999993	_____	1000007	3.00000E-05	>10:1
4MHz	.512	3999974	_____	4000026	1.20000E-04	>10:1
10MHz	.256	9999936	_____	10000064	3.00000E-04	>10:1
20MHz	.128	19999872	_____	20000128	6.00000E-04	>10:1
50MHz	.064	49999684	_____	50000316	1.50000E-03	>10:1
100MHz	.032	99999369	_____	100000631	3.00000E-03	>10:1
100MHz	.016	99999337	_____	100000663	3.00000E-03	>10:1
100MHz	.008	99999275	_____	100000725	3.00000E-03	>10:1
100MHz	.004	99999149	_____	100000851	3.00000E-03	>10:1
100MHz	.002	99998899	_____	100001101	3.00000E-03	>10:1
100MHz	65.536	99999400	_____	100000600	3.00000E-03	>10:1
Channel 2						
100 MHz	.002	99998899	_____	100001101	3.00000E-03	>10:1
Channel 3						
75 MHz	.128	74999050	_____	75000950	2.25000E-03	>10:1
100 MHz	.064	99998400	_____	100001600	3.00000E-03	>10:1
200 MHz	.032	199996800	_____	200003200	6.00000E-03	>10:1
400 MHz	.016	399993600	_____	400006400	1.20000E-02	>10:1
600 MHz	.008	599988400	_____	600011600	1.80000E-02	>10:1
900 MHz	.004	899978600	_____	900021400	2.70000E-02	>10:1
1 GHz	.002	999962000	_____	1000038000	3.00000E-02	>10:1

Table 4-8. Performance Test Record for the HP E1333A Counter (Page 4 of 4)

Model _____	Report No. _____	Date _____
-------------	------------------	------------

Period Measurements (Channel 1)

Source Period	Period Avgd	Low Limit (sec)	Measured Period (sec)	High Limit (sec)	Meas Uncert (sec)	Test Acc Ratio
1 sec	2	9.9858948E-01	_____	1.0014105E+0	3.00000E-11	>10:1
100 msec	4	9.9929151E-02	_____	1.0007085E-01	3.00000E-12	>10:1
10 msec	8	9.9964163E-03	_____	1.0003584E-02	3.00000E-13	>10:1
1 msec	16	9.9981219E-04	_____	1.0001878E-03	3.00000E-14	>10:1
200 usec	32	1.9997812E05	_____	2.0002188E-04	6.00000E-15	>10:1
100 usec	64	9.9993449E-05	_____	1.0000655E-04	3.00000E-15	>10:1
20 usec	128	1.9998660E-05	_____	2.0001340E-05	6.00000E-16	>10:1
10 usec	256	9.9994397E-06	_____	1.0000560E-05	3.00000E-16	>10:1
2 usec	512	1.9997817E-06	_____	2.0002183E-06	6.00000E-17	>10:1
1 usec	1024	9.9989360E-07	_____	1.0001064E-06	3.00000E-17	>10:1
500 nsec	2048	4.9994749E-07	_____	5.0005251E-07	1.50000E-17	>10:1
200 nsec	4096	1.9997425E-07	_____	2.0002575E-07	6.00000E-18	>10:1
100 nsec	8192	9.9987159E-08	_____	1.0001284E-07	3.00000E-18	>10:1

Pulse Width Measurements (Channel 1: 2 Periods Averaged)

Pulse Width	Pulse Polarity	Low Limit (msec)	Measured Width (msec)	High Limit (msec)	Meas Uncert (sec)	Test Acc Ratio
1 sec	POS	997.18500	_____	1002.81500	3.00000E-11	>10:1
1 sec	NEG	997.18500	_____	1002.81500	3.00000E-11	>10:1
1 msec	POS	.99714	_____	1.00286	3.00000E-14	>10:1
1 msec	NEG	.99714	_____	1.00286	3.00000E-14	>10:1
1 sec	POS	997.18500	_____	1002.81500	3.00000E-11	>10:1
1 sec	NEG	997.18500	_____	1002.81500	3.00000E-11	>10:1
1 msec	POS	.99714	_____	1.00286	3.00000E-14	>10:1
1 msec	NEG	.99714	_____	1.00286	3.00000E-14	>10:1

Time Interval Measurements (Channels 1 and 2: 1 Period Averaged)

Ch	Ch 1 Edge	Ch 2 Edge	Time Interval (nsec)	Low Limit (nsec)	Measured Interval (nsec)	High Limit (nsec)	Meas Uncert (sec)	Test Acc Ratio
1	POS	NEG	500	397.191	_____	602.809	1.500000E-17	>10:1
2	NEG	POS	500	397.191	_____	602.809	1.500000E-17	>10:1

Introduction

This chapter contains procedures to adjust the HP E1333A Counter, including the 10 MHz reference oscillator frequency, Channel 1 trigger level zero, and channel 2 trigger level zero.

Adjustment Requirements

The counter should be adjusted after repair to ensure peak performance. Equipment required for the adjustment procedures is listed in Table 1-2, "Recommended Test Equipment." In addition, you will need a small slotted screwdriver, a Phillips (or Pozidriv) screwdriver, and a T10 torx key.

Before performing adjustments, the counter must have a minimum 60-minute warm up and the line voltage must be 115/230 Vac $\pm 10\%$. For best accuracy, the test area temperature should be between 18°C and 28°C, and stable to $\pm 1^\circ\text{C}$.

WARNING

Remove the power cord and all other sources of power supplied (via other plug-in modules) to the mainframe. When installation is complete, cover all unused slots and ensure that all module faceplates are secured tightly against the mainframe.

Only qualified, service-trained personnel should install or change the location of the HP E1333A (or any other plug-in module) inside the HP 75000 Series B mainframe.

Adjustment Access

To perform the reference oscillator and trigger level zero adjustments, ensure that the components to be adjusted (R10, R11, and U7) are accessible. There are two main ways to do this (you can also install the counter in an HP E1400T mainframe):

- One way is to remove all other modules in the mainframe and place the counter in a slot that allows access to the components.
- The other way is to remove the mainframe top cover and/or any internal covers required to access the components. See the appropriate mainframe service manual and/or configuration guide for instructions.

Reference Oscillator Adjustment

This adjustment sets the 10 MHz reference oscillator output to $10\text{ MHz} \pm 10\text{ Hz}$ ($\pm 1\text{ ppm}$). The procedure is:

1. Connect Channel A of the HP 5334B Universal Counter to the output of the 10 MHz reference oscillator (U53 pin 13) (see Figure 5-1).
2. Set the HP 5334B counter to measure frequency on Channel A.
3. Reset the HP E1333A with *RST.
4. Use a slotted screwdriver to adjust the U7 potentiometer until the HP 5334B shows $10\text{ MHz} \pm 10\text{ Hz}$.

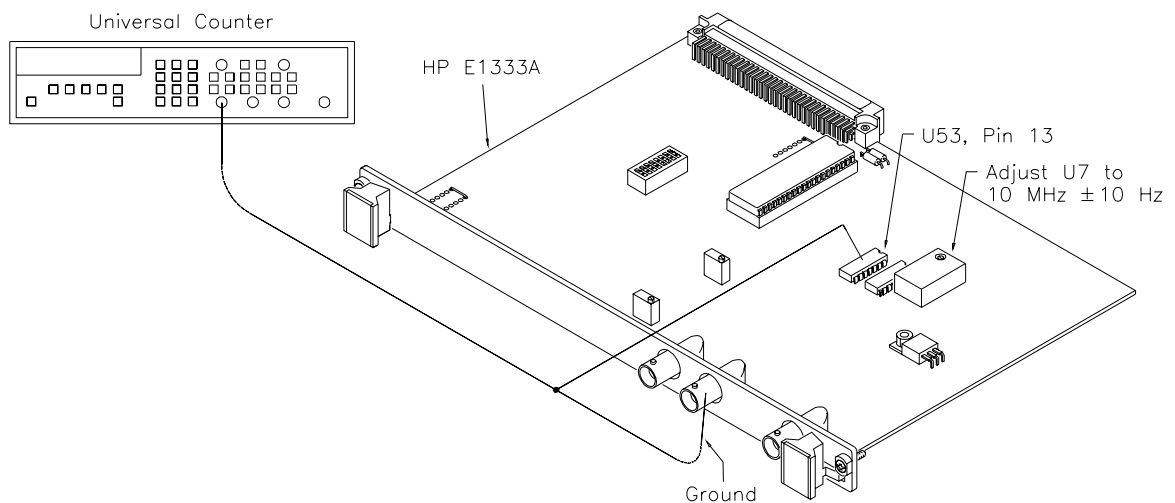

Figure 5-1. Reference Oscillator Adjustments

Trigger Level Zero Adjustments

This procedure adjusts the crossing point for 0V level triggering on Channels 1 and 2. The procedure is:

1. For Channel 1 trigger level zero adjustments, connect an oscilloscope between U2 pin 5 and the HP E1333A input Common, and connect the HP 3325A output to Channel 1 (see Figure 5-2).
2. Output a 1 Vac PP triangle wave at 10 kHz from the HP 3325A to Channel 1 of the HP E1333A. You should see a square wave.
3. Adjust potentiometer R11 until the positive and negative pulses of the square wave are equal in width.
4. Repeat steps 2 and 3 with triangle waves of amplitudes of 250 mV PP and 50 mV PP. The adjustment becomes more accurate as the input amplitude becomes smaller.
5. For Channel 2 adjustments, repeat steps 1 through 4 except connect the HP 3325A output to Channel 2, connect the oscilloscope to U2 pin 12 and the input Common, and adjust R10.

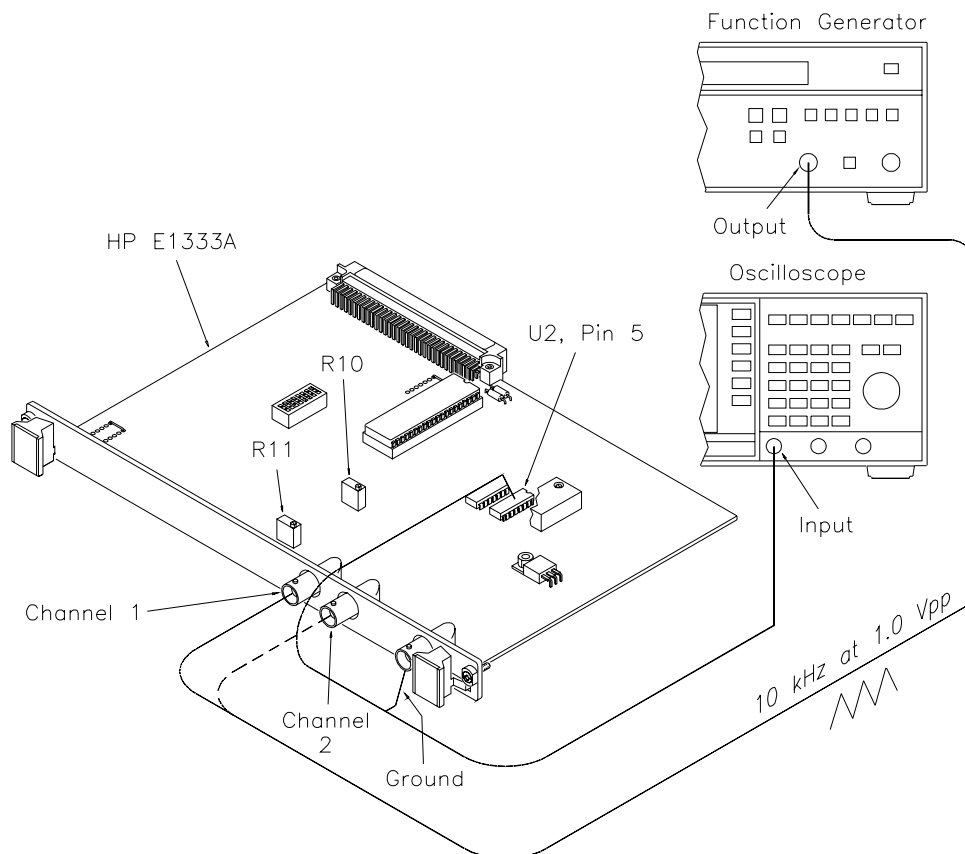

Figure 5-2. Trigger Level Zero Adjustments

Introduction

This chapter contains information to order replaceable parts for the HP E1333A counter.

Exchange Assemblies

Table 6-1 lists assemblies that may be replaced on an exchange basis (EXCHANGE ASSEMBLIES). Exchange, factory-repaired, and tested assemblies are available only on a trade-in basis. Defective assemblies must be returned for credit. Assemblies required for spare parts stock must be ordered by the new assembly part number. Contact your nearest Hewlett-Packard Sales and Service Office for details.

Ordering Information

To order a part listed in Table 6-1, specify the Hewlett-Packard part number, the check digit (CD), and the quantity required. Send the order to your nearest Hewlett-Packard Sales and Service Office. (Using the check digit will help ensure accurate processing of your order.)

Replaceable Parts List

Tables 6-1 lists the replaceable parts for the HP E1333A counter.
See Figure 6-1 for locations of parts listed in Table 6-1.

Table 6-1. HP E1333A Replaceable Parts

Reference* Designator	HP Part Number	CD	Qty	Description
	E1333-66201	8	1	EXCHANGE ASSEMBLIES 3-CHAN UNIVERSAL COUNTER (NEW) 3-CHAN UNIVERSAL COUNTER (EXCH)
	E1333-69201	4	1	
A1	E1333-66501	0	1	PRINTED CIRCUIT ASSY [a]
A1BRK1	0500-2183	1	2	BRACKET-RIGHT ANGLE,MTG;PNL-PCB RIVET-SEMITUBULAR .095 DIA .406 LNG
	0361-1295	3	2	
A1BRK2	0500-2183	1		BRACKET-RIGHT ANGLE,MTG;PNL-PCB RIVET-SEMITUBULAR .095 DIA .406 LNG
	0361-1295	3		
A1F1	2110-0712	8	3	FUSE-SUBMINIATURE 4A 125V NTD AX
A1F2	2110-0712	8		FUSE-SUBMINIATURE 4A 125V NTD AX
A1F2	2110-0712	8		FUSE-SUBMINIATURE 4A 125V NTD AX
A1J1	1250-1846	6	3	CONNECTOR-RF BNC FEM PC 50-OHM
A1J2	1250-1846	6		CONNECTOR-RF BNC FEM PC 50-OHM
A1J3	1250-1846	6		CONNECTOR-RF BNC FEM PC 50-OHM
A1JM1	7175-0057	5	2	RESISTOR-ZERO OHMS TND COPPER
A1JM2	7175-0057	5		RESISTOR-ZERO OHMS TND COPPER
A1MP1	0570-1295	6	1	STUD-PRSN M3.0 X .56 MM LONG
A1MP2	0535-0004	9	1	NUT-HEX DBL-CHAN M3X0.5 2.9 MM THK
A1MP3	2190-0584	0	1	WASHER-LK HLCL 3.0 MM 3.1-MM-ID
A1P1	1252-1596	7	1	CONN-POST-TYPE;2.54-PIN-SPCG96-CONT
	0361-1294	2	2	RIVET-SEMITUBULAR .095 DIA .328 LNG
A1SW1	3101-3066	3	1	SWITCH-DIP RKR SPST 0.1A 5VDC
A1XU14	1200-0817	4	1	SOCKET-IC 40-CONT DIP DIP-SLDR
				MECHANICAL PARTS
MP1	E1300-45101†		1	HNDL-KIT TOP, HP†
MP2	E1300-45102†		1	HNDL-KIT BTM, VXI†
PNL1	E1333-00202†		1	PNL-RR CENTER 4 CH†
SCR1-SCR2	0515-2140		2	SCR-THD-RLG M2.5 X0.45 14mm
SCR5-SCR6	0515-2743		2	SCR-FH M2.5 X 8 THREAD ROLLING

* See Table 6-2 for Reference Designator definitions.

[a] Repair limited to replacement of parts listed - see Introduction for ordering information

† These parts are not compatible with older version fixed handles and their corresponding front panels. To replace one or more of these older parts, you must order all three new parts (Top and Bottom Handle Kits AND Front Panel).

Table 6-2. HP E1333A Reference Designators

HP E1333A Reference Designators			
A	assembly	P	electrical connector (plug)
BRK	bracket	PNL	panel
F	fuse	SCR	screw
J	electrical connector (jack)	SW	switch
JM	electrical connector (jumper)	XU	socket, integrated circuit
MP	misc. mechanical part		

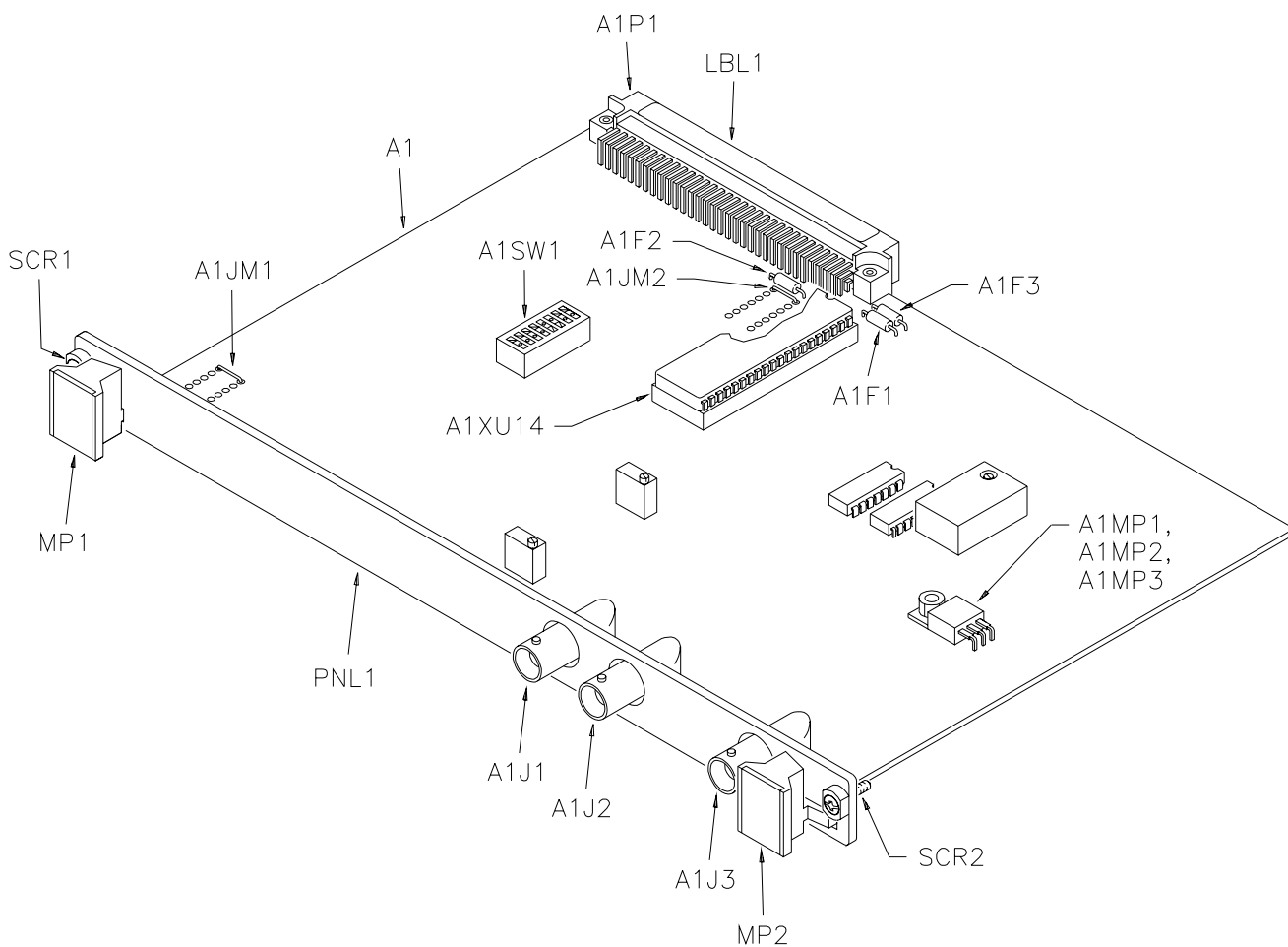

Figure 6-1. HP E1333A Counter - Replaceable Parts

Introduction

This chapter contains information to service the HP E1333A counter, including troubleshooting guidelines and repair/maintenance guidelines.

WARNING Do not perform any of the service procedures shown unless you are a qualified, service-trained person, and have read the **WARNINGS** and **CAUTIONS** in Chapter 1.

Equipment Required

Equipment required for counter troubleshooting and repair is listed in Table 1-2, "Recommended Test Equipment." To avoid damage to the screw head slots, use Pozidrive or Torx drivers as required. You may need Torx size T-8 (8710-1673), size T-10 (8710-1284), and size T-15 (8710-1816) screwdrivers. For adjustments to R10 and R11 (see Chapter 5, "Adjustments"), use a blade tuning tool (8710-0033) or JFD Model 5284 (8710-1010) hex tuning tool.

Service Aids

Service aids on printed circuit boards include pin numbers, some reference designations, and assembly part numbers. See Chapter 6, "Replaceable Parts," for descriptions and location of HP E1333A replaceable parts.

Service notes, manual updates, and service literature for the HP E1333A counter may be available through Hewlett-Packard. For information, contact your nearest Hewlett-Packard Sales and Service Office.

Troubleshooting Techniques

There are two main steps to troubleshoot an HP E1333A counter problem: (1) identify the problem, and (2) test assemblies to isolate the cause to a user-replaceable component.

Identifying the Problem

Counter problems can be divided into four general categories:

- Self-test errors
- Operator errors
- Catastrophic failures
- Performance out of specification

Self-Test Errors

An error number (1 through 7) is returned when the counter self-test fails. If a self-test error occurs, recycle power and repeat the self-test. If the error repeats, see the following section "Testing the Counter" to troubleshoot the counter. Table 7-1 shows some typical causes of self-test errors.

Table 7-1. Self-Test Errors

Error	Description	Typical Causes
0	Self-Test Passed	
1	Counter did not power up properly	-Bad connections/settings -A1F1, F2, or F3 open -Hardware failure (exchange)
2	Problem with digital portion of trigger level	-Hardware failure (exchange)
3	Counter did not properly measure frequency	-Hardware failure (exchange)
4	Counter did not properly measure period	-Hardware failure (exchange)
5	Counter did not properly totalize	-Hardware failure (exchange)
6	Problem with analog portion of trigger level	-Hardware failure (exchange)
7	Counter is not in proper state after being reset	-Incorrect operation -Hardware failure (exchange)

Operator Errors

Apparent failures may result from operator errors. See Appendix B, "Error Messages," in the *HP E1333A User's Manual* for information on operator errors.

Catastrophic Failure

If a catastrophic failure occurs, see "Testing the Counter" below to troubleshoot the counter.

Performance Out of Specification

If the counter performance is out of specification limits, use the adjustment procedures in Chapter 5, "Adjustments," to correct the problem. If the condition repeats, see "Testing the Counter" below to troubleshoot the counter.

Testing the Counter

You can use the tests and checks in Table 7-2 to isolate the problem to a user-replaceable part on the counter front panel or to the A1 PCA. See Figure 6-1 in Chapter 6, "Replaceable Parts," for locations of user-replaceable parts.

NOTE

If the problem cannot be traced to a user-replaceable part listed in Table 6-1, return the counter to Hewlett-Packard for exchange. See Chapter 6, "Replaceable Parts," for procedures.

Table 7-2. HP E1333A Tests/Checks

Test/Check	Reference Designator	Check:
Heat Damage	-----	Discolored PC boards Damaged insulation Evidence of arcing
Switch/Jumper Settings	JM1, JM3 SW1	IRQ Level setting LADDR setting
A1 Assembly	F1, F2, F3 J1, J2, J3 P1 XU14	Fuse continuity Mating connector contacts Connector contacts IC contact/connections

Checking Heat Damage

Inspect the counter for signs of abnormal internally generated heat such as discolored printed circuit boards or components, damaged insulation, or evidence of arcing. If there is damage, do not operate the counter until you correct the problem.

Checking Switches/Jumpers

Verify the logical address setting is set correctly (factory set at 48). Verify the interrupt priority jumpers are set correctly (factory set at level 1). See the *HP E1333A User's Manual* for information.

Testing the A1 Assembly

To test the A1 Assembly, remove mainframe power and remove the counter from the mainframe. Then, see table 7-2 for guidelines to isolate the problem to a user-replaceable part.

Repair/Maintenance Guidelines

This section gives guidelines to repair and maintain the HP E1333A counter, including:

- ESD precautions
- Soldering printed circuit boards
- Post-repair safety checks

ESD Precautions

Electrostatic discharge (ESD) may damage MOS, CMOS and other static sensitive devices in the HP E1333A counter. This damage can range from slight parameter degradation to catastrophic failure. When handling counter assemblies, follow these guidelines to avoid damaging counter components:

- Always use a static-free work station with a pad of conductive rubber or similar material when handling counter components.
- After you remove the counter from the mainframe, place the counter on a conductive surface to guard against ESD damage.
- Do not use pliers to remove a MOS or CMOS device from a high-grip socket. Instead, use a small screwdriver to pry the device up from one end. Slowly lift the device up, one pair of pins at a time.

- After you remove a MOS or CMOS device from an assembly, place the device onto a pad of conductive foam or other suitable holding material.
- If a device requires soldering, be sure the assembly is placed on a pad of conductive material. Also, be sure you, the pad, and the soldering iron tip are grounded to the assembly. Apply as little heat as possible when soldering.
- When you replace a MOS or CMOS device, ground the foam to the counter before removing the device from the foam.

The etched circuit boards in the counter have plated through-holes that allow a solder path to both sides of the insulating material. Soldering can be done from either side of the board with equally good results. When soldering to any circuit board, keep in mind the following guidelines.

CAUTION

Do not use a sharp metal object such as an awl or twist drill, since sharp objects may damage the plated-through conductor.

- Avoid unnecessary component unsoldering and soldering. Excessive replacement can result in damage to the circuit board and/or adjacent components.
- Do not use a high power soldering iron on etched circuit boards (a 38-watt soldering iron is recommended), as excessive heat may lift a conductor or damage the board.
- Use a suction device or wooden toothpick to remove solder from component mounting holes. When using a suction device, be sure the equipment is properly grounded to prevent electrostatic discharge from damaging CMOS devices.

Post-Repair Safety Checks

After making repairs to the HP E1333A counter, inspect the counter for any signs of abnormal internally generated heat, such as discolored printed circuit boards or components, damaged insulation, or evidence of arcing. Determine and correct the cause of the condition. Then run the self-test (*TST? command) to verify that the counter is functional.

Appendix A

Counter Accuracy Calculations

Introduction

This appendix shows how counter accuracy is defined and calculated for the HP E1333A 3-Channel Counter. See Table 4-8, "Performance Test Record," for the HP E1333A Counter, for values of counter accuracy.

Counter accuracy is defined as the expected accuracy of the measurement due ONLY to the HP E1333A counter. The "Low Limit" entry in Table 4-8 corresponds to the lower (-) value of counter accuracy, while the "High Limit" entry in Table 4-8 corresponds to the upper (+) value of counter accuracy.

For further information on counter accuracy specifications, see Application Note 200, "Fundamentals of Electronic Counters" (HP part number 02-5952-7506) and Application Note 200-4, "Understanding Frequency Counter Specifications" (HP part number 02-5952-7522).

Calculating Counter Accuracy

For the HP E1333A counter, accuracy is defined for Frequency Measurements, Period Average Measurements, Pulse Width Measurements, and Time Interval Measurements by the following equation:

$$\text{accuracy} = \pm [\text{resolution} + \text{timebase error} + \text{trigger noise error}]$$

Resolution is defined as the smallest change in the measurement that can be detected. For frequency measurements, resolution is in Hz. For period average, pulse width, and time interval measurements, resolution is in seconds (see Table A-1).

NOTE For Channel 3 frequency accuracy calculations, frequency resolution = $64/\text{aper time}$.

Table A-1. HP E1333A Counter Resolution Equations

Measurement	Resolution	Range/values
Frequency	$\frac{1^*}{aper\ time}$ (Hz)	.002, .004, ..., 65.536 sec
Period Average	$\frac{100}{\# periods\ avgd}$ (nsec)	2, 4, 8, ..., 65536 periods
Pulse Width/ Time Interval	$\frac{100}{\# periods\ avgd}$ (nsec)	1, 2, 4, ..., 128 periods

*For Channel 3 only, frequency resolution (Hz) = 64/aper time

Timebase error is defined as the maximum fractional change in the 10 MHz reference timebase frequency due to all error sources, which we will call the **timebase** (initial accuracy, aging, and temperature drift), multiplied by the measurement result. That is:

$$\text{timebase error} = \pm [\text{initial accuracy} + \text{aging rate} + \text{temperature drift}] \times \text{measurement result.}$$

For the HP E1333A, the *worst-case* timebase values are initial accuracy = ± 2 ppm, aging rate = ± 2 ppm/year, and temperature drift = ± 5 ppm, 0°C to 50°C. However, typical maximum temperature drift is about 2 ppm (see Figure A-1), and calibration is usually performed at 1-year intervals. Thus, a typical timebase error = $\pm (2 \times 10^{-6} + 2 \times 10^{-6} + 2 \times 10^{-6}) = \pm (6 \times 10^{-6}) \times$ measurement result.

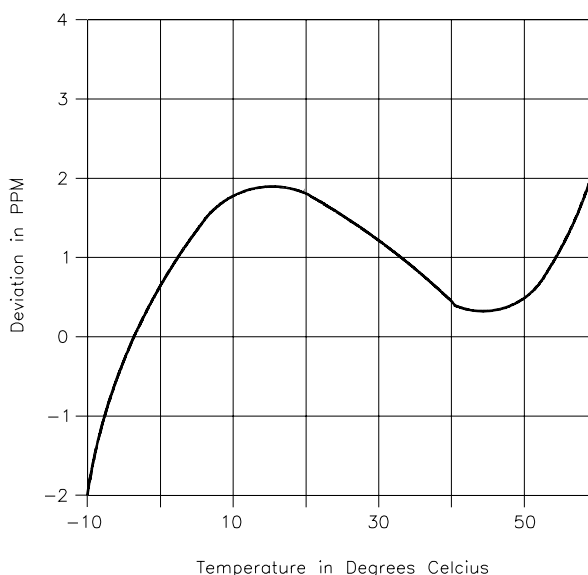

Figure A-1. Typical Temperature Drift

Trigger Noise Error

Trigger noise error is defined as the additional error caused by counter input noise (80 μV for the HP E1333A) and by noise on the input signal. The *input slew rate at trigger point* (in $\mu\text{V}/\text{sec}$) is the rate at which the input voltage is changing when the input is triggered. That is:

$$\text{slew rate} = \frac{\Delta V}{\Delta t}$$

For example, for a 50 mV ramp wave input with a 10 μsec rise time,

$$\text{slew rate} = \frac{0.8 \times 50 \times 10^{-3}}{10 \times 10^{-6}} = 4 \times 10^3 \text{V}/\text{sec} = 4 \times 10^9 \mu\text{V}/\text{sec}$$

Typically, however, the slew rate is not a constant, but varies linearly with the input frequency, according to the **slew rate factor**. That is, **slew rate = slew rate factor x frequency = slew rate factor/period**. For example, a typical slew rate factor for a 50 mV input signal is 0.5 (for slew rate in V/sec). Thus, for a 50 mV input at 10 kHz, a typical **slew rate = 0.5 x 10⁴ V/sec = 5000 V/sec = 5 x 10⁹ $\mu\text{V}/\text{sec}$** .

Frequency Measurements Trigger Noise Error

From Appendix A, "Specifications," of the *HP E1333A User's Manual*, for frequency measurements:

Trigger Noise Error (RMS) = T, where:

$$T = \frac{\sqrt{(80\mu\text{V})^2 + (e_n)^2}}{\text{input slew rate at trigger point}}$$

e_n = rms noise (in μV) on the input signal for a 150 MHz bandwidth.

However, T is NOT the "trigger noise error" term for frequency measurements accuracy, but is only part of the equation. From Application Note 200-4, for frequency measurements:

$$\begin{aligned} &\text{trigger noise error (Hz)} \\ &= [(1.4 \times T)/\text{aper time}] \times \text{frequency} \\ &= 1.4 \times \frac{\sqrt{(80\mu\text{V})^2 + (e_n)^2}}{\text{input slew rate at trigger point}} \times \text{frequency} \end{aligned}$$

Period Measurements Trigger Noise Error

From Appendix A, "Specifications," of the *HP E1333A User's Manual*, for period, pulse width, and time interval measurements:

Trigger Noise Error (RMS) = T, where T is:

$$T = \frac{\sqrt{(80\mu V)^2 + (e_n)^2}}{\text{input slew rate at trigger point}}$$

However as with frequency measurements, T is NOT the "trigger noise error" term for period measurements, but is only part of the equation. For period average, pulse width, and time interval measurements, **trigger noise error = (1.4 x T)/nper**, where nper = number of periods averaged. Therefore:

trigger noise error (sec) =

$$1.4 \times \frac{\sqrt{(80\mu V)^2 + (e_n)^2}}{\text{nper} \times \text{input slew rate at trigger point}}$$

Counter Accuracy Equations Table

Table A-2 summarizes counter accuracy equations for frequency, period average, pulse width, and time interval measurements. For any listed measurement, **accuracy = ±[resolution + timebase error + trigger noise error]**.

Table A-2. HP E1333A Counter Accuracy Equations

Measurement	± resolution	± timebase error*	± trigger noise error**
Frequency	$\frac{1}{\text{aper time}}$ (Hz) (.002, .004, ..., 65.536 sec)	timebase x frequency (Hz)	$\frac{1.4 \times T}{\text{aper time}} \times \text{frequency}$ (Hz)
Period Average	$\frac{100}{\# \text{ periods avgd}}$ (nsec) (2, 4, 8, ..., 65536 periods)	timebase x period (sec)	$\frac{1.4 \times T}{\# \text{ periodsavgd}}$ (sec)
Pulse Width	$\frac{100}{\# \text{ periods avgd}}$ (nsec) (1, 2, 4, ..., 128 periods)	timebase x pulse width (sec)	Same as Period
Time Interval	Same as Pulse Width	timebase x interval (sec)	Same as Period

* timebase = ± [initial accuracy + aging rate + temp drift] = 6.0 x 10⁻⁶ (typical)

** T = $\frac{\sqrt{(80\mu V)^2 + (e_n)^2}}{\text{input slew rate at trigger point}}$

Accuracy Calculations Examples

Two examples follow to calculate HP E1333A counter accuracy. The first example calculates frequency measurement accuracy, while the second example calculates period measurement accuracy.

Example: Calculating Frequency Accuracy

For this example, assume the following values/conditions:

Input frequency: 10 kHz sine wave
Input amplitude: 50 mV rms
Aper time: 4.096 sec
Timebase: 6.0×10^{-6}
Source noise (e_n): 1 mV rms
Slew rate: 0.5 x frequency (V/sec)

NOTE

The source noise of 1 mV is a typical value. You will need to measure the noise of your source for most accurate calculations.

Frequency Measurement Accuracy Equation

For frequency measurements: **accuracy** (Hz) = \pm [resolution + timebase error + trigger noise error].

Calculate Resolution

For an aperture time of 4096 msec, **resolution** = $\pm 1/\text{aper time} = \pm 1/(4.096) = \pm 0.2441$ Hz

Calculate Timebase Error

For frequency measurements, **timebase error** = timebase x frequency = \pm [initial accuracy + aging rate + temp drift] x frequency = $\pm (6.0 \times 10^{-6}) \times 10^4$ Hz = ± 0.06 Hz

Calculate Trigger Noise Error

From Table A-2, for frequency measurements:

$$\text{trigger noise error (Hz)} = \pm \frac{1.4 \times T}{\text{aper time}} \times \text{frequency}$$

$$\text{where } T = \frac{\sqrt{(80\mu\text{V})^2 + (e_n)^2}}{\text{input slew rate at trigger point}}$$

e_n = rms noise (in μV) on the input signal

Thus, for input noise $e_n = 1 \text{ mV}$, aper time = 4.096 sec, and slew rate = $0.5 \times 10^4 \text{ V/sec}$ ($5 \times 10^9 \mu\text{V/sec}$), the trigger noise error for a 10 kHz input is:

trigger noise error (Hz)

$$\begin{aligned} &= \pm 1.4 \times \frac{\sqrt{(80\mu\text{V})^2 + (1000\mu\text{V})^2}}{4.096 \text{ sec} \times 5 \times 10^9 \mu\text{V/sec}} \times 10^4 \text{ Hz} \\ &= \pm 1.686 \times 10^{-3} \text{ Hz} = \pm 0.000686 \text{ Hz} \end{aligned}$$

Calculate Frequency Measurement Accuracy

Since **accuracy** (frequency measurements) = \pm [resolution + timebase error + trigger noise error]

$$\begin{aligned} \text{accuracy} &= \pm (0.2441 \text{ Hz} + 0.06 \text{ Hz} + 0.000686 \text{ Hz}) \\ &= \pm 0.3048 \text{ Hz} \end{aligned}$$

Effects of Varying Signal Conditions

Although this example showed resolution as the primary contributor to counter accuracy, timebase errors can also be a major contributor, as shown in Table A-3. For Case 1, the resolution error contributes about 79% of the error. However, for Case 2 the timebase error contributes about 99% of the error. For Case 3, triggering is assumed to NOT be at the midpoint of the sine wave, and a slew rate of 1 V/sec is assumed. However, even with a very slow slew rate, the trigger noise error is only about 0.14%.

Table A-3. Effects on Frequency Accuracy of Varying Input Conditions

Case	Freq	Aper Time (sec)	Slew Rate (V/sec)	Resolution (Hz)	Timebase Error (Hz)	Trigger Error (Hz)	Counter Acc (Hz)
1	10 kHz	4.096	10^3	0.2441 (79%)	0.06	3.43×10^{-3}	0.3076
2	10 MHz	32.768	10^6	0.0305	60.0 (99%)	4.29×10^{-4}	60.0309
3	1 Hz	4.096	1	0.2441 (99%)	6×10^{-6}	3.43×10^{-4}	0.2445

NOTE

Although the combinations shown in Table A-3 do not necessarily reflect actual test conditions, the numbers do indicate that a careful analysis of the input signal and triggering points is required to determine the accuracy of your measurements.

**Example: Calculating
Period Average
Accuracy**

For this example, assume the following values/conditions:

Input period: 200 μ sec (5 kHz sine wave)

Number periods averaged: 32

Timebase: 6.0×10^{-6}

Source amplitude: 50 mV rms

Source Noise (e_n): 1 mV rms

Slew rate: 0.5/period (V/sec)

NOTE

The source noise of 1 mV is a typical value. You will need to measure the noise of your source for most accurate calculations. You can use this example for time interval and pulse width measurements by substituting the appropriate equations shown in Table A-2.

Period Measurement Accuracy Equation

For period measurements, **accuracy** (sec) = \pm [resolution + timebase error + trigger noise error].

Calculate Resolution

For 32 periods to be averaged, **resolution** = $\pm (100/nper) = \pm (100/32) = \pm 3.125$ nsec

Calculate Timebase Error

For period measurements, **timebase error** (sec) = timebase x period = \pm [initial accuracy + aging rate + temp drift] x period. For this example, timebase error = $\pm (6.0 \times 10^{-6}) \times (200 \times 10^{-6}) = \pm 1.2$ nsec.

Calculate Trigger Noise Error

From Table A-1, **trigger noise error** (sec) = 1.4 x T/nper, where:

$$T = \frac{\sqrt{(80\mu V)^2 + (e_n)^2}}{\text{input slew rate at trigger point}}$$

For a 1 mV rms input noise, 32 periods averaged, and slew rate = 0.5/200 x 10⁻⁶ = 2500 V/sec (2.5 x 10⁹ μV/sec):

trigger noise error (sec) =

$$\pm 1.4 \times \frac{\sqrt{(80\mu V)^2 + (1000\mu V)^2}}{32 \times 2.5 \times 10^9 \mu V/sec} = \pm 17.556 \text{ nsec}$$

Calculate Period Average Measurement Accuracy

accuracy (period average measurements)

= ± [resolution + timebase error + trig noise error]

= ± (3.125 nsec + 1.2 nsec + 17.556 nsec) = ± 21.881 nsec

Effects of Varying Signal Conditions

Although this example showed trigger noise error as the primary contributor to counter accuracy, resolution errors and timebase errors can also be major contributors, as shown in Table A-4. For Case 1, the resolution error contributes about 88% of the error. However, for Case 2 the timebase error contributes about 86% of the error. For Case 3, triggering is assumed to NOT be at the midpoint of the sine wave. With a (slow) slew rate of 100 V/sec, the trigger noise error is about 99% of the total error.

Table A-4. Effects on Period Accuracy of Varying Input Conditions

Case	Period (sec)	Periods Avgd	Slew Rate (V/sec)	Resolution (nsec)	Timebase Error (nsec)	Trigger Error (nsec)	Counter Acc (nsec)
1	1 x 10 ⁻³	2	10 ⁶	50.000 (88%)	6.000	0.7022	56.702
2	2 x 10 ⁻³	128	10 ⁴	.7813	12.000 (86%)	1.0972	13.879
3	5 x 10 ⁻⁷	2048	10 ²	.0488	.0030	6.8578 (99%)	6.909

Counter Accuracy Programs

Two programs follow to calculate counter accuracies. After you enter the parameter values, the program computes the appropriate measurement accuracies and prints the results. The programs are designed for HP 9000 Series 200/300 computers using HP BASIC.

Frequency Measurement Accuracy

To make frequency measurement accuracy calculations, first enter the desired number of accuracy calculations you want to make (up to 100 sets of calculations). Then, for each calculation enter the desired values for:

- Frequency (Hz)
- Aperi time (sec)
- Timebase
- Source noise (V rms)
- Slew rate (V/sec)

The program calculates frequency measurement accuracy for each set of input values and prints or displays the results. A typical display follows the program listing.

NOTE

If you want to make more than 100 calculations, change the DIM statement (line 40) for the number of calculations required. Also, if your printer address is not 701, change line 30 PRINTER IS 701 to your printer address. If you do not want to use a printer, change line 30 to 30 PRINTER IS 1.

Program Listing

```
10 Calc_no = 0
20 OPTION BASE 1
30 PRINTER IS 701
40 DIM Freq (100),Aper(100),Timebase(100),Noise(100),
Slewrates(100),Accuracy(100)
50 INPUT " Select number of calculations (1 to 100) ",Calc_no
60 FOR I = 1 TO Calc_no
70 CLEAR SCREEN
80 OUTPUT CRT;"Select values for frequency accuracy calculation
number";I
90 INPUT " Frequency (Hz) = ",Freq(I)
100 INPUT " Aperi time (sec) = ",Aper(I)
110 INPUT " Timebase = ",Timebase(I)
120 INPUT " Source noise (V rms) = ",Noise(I)
```

Continued on Next Page

```

130 INPUT " Slew rate (V/sec) = ",Slewrte(l)
140 Accuracy(l)=1/Aper(l)+Timebase(l)*Freq(l) + 1.4*Freq(l) *
(SQRT((8.0E-5 ^ 2 + Noise(l) ^ 2))/(Slewrte(l) *Aper(l)))
150 NEXT I
160 CLEAR SCREEN
170 PRINT "Frequency Measurement Accuracy (Hz)"
180 PRINT
190 PRINT
200 Format:IMAGE 10A,4X,10A,2X,12A,X,14A,2X,12A,3X,8A
210 PRINT USING Format;"Frequency";"AperTime"; "Timebase"; "Source
Noise";"Slew Rate";"Accuracy"
220 PRINT USING Format;"(Hz)";"(sec)";"";"(V rms)";"(V/sec)";"(Hz)"
230 PRINT
240 FOR I = 1 TO Calc_ no
250 Format1:IMAGE D.5DE,3X,2D.3D,3X,D.5DE,3X,D.5DE,
4X,D.5DE,3X,2A,D.5DE
260 PRINT USING Format1;Freq(l);Aper(l);Timebase(l);
Noise(l);Slewrte(l);CHR$(254);Accuracy(l)
270 NEXT I
280 END

```

Typical display

Frequency Measurement Accuracy (Hz)

Frequency (Hz)	Aper Time (sec)	Timebase	Source Noise (v rms)	Slew Rate V/sec)	Accuracy (Hz)
1.00000E+04	4.096	6.00000E-6	1.00000E-03	1.00000E+03	± 3.07570E-01

Period Measurements Accuracy

To make period/pulse width/time interval accuracy calculations, enter the number of accuracy calculations you want to make (up to 100 sets of calculations). Then, for each calculation enter the desired values for:

- Period/pulse width/time interval (sec)
- Number of periods averaged
- Timebase
- Source noise (V rms)
- Slew rate (V/sec)

The program calculates period, pulse width, or time interval measurement accuracy for each set of input values and displays the results. A typical display follows the program listing.

NOTE

If you want to make more than 100 calculations, change the DIM statement (line 40) for the number of calculations required. Also, if your printer address is not 701, change line 30 PRINTER IS 701 to your printer address. If you do not want to use a printer, change line 30 to 30 PRINTER IS 1.

Program Listing

```
10 Calc_no=0
20 OPTION BASE 1
30 PRINTER IS 701
40 DIM Period(100),Nper(100),Timebase(100),Noise(100),
Slewrates(100),Accuracy(100)
50 INPUT " Select number of calculations (1 to 100) ",Calc_no
60 FOR I = 1 TO Calc_no
70 CLEAR SCREEN
80 OUTPUT CRT;"Select values for period/PW/TI calculation number";I
90 INPUT " Period/pulse width/time interval (sec) = ",Period(I)
100 INPUT " Number periods averaged = ",Nper(I)
110 INPUT " Timebase = ",Timebase(I)
120 INPUT " Source noise (V rms) = ",Noise(I)
130 INPUT " Slew rate (V/sec) = ",Slewrates(I)
140 Accuracy(I) = 1.E-7/Nper(I) +Timebase(I)*Period(I) +
1.4*(SQRT((8.0E-5 ^ 2 + Noise(I) ^ 2))/(Nper(I)*Slewrates(I)))
150 NEXT I
160 CLEAR SCREEN
170 PRINT "Period /Pulse Width/Time Interval Measurement Accuracy
(sec)"
180 PRINT
190 PRINT
200 Format:IMAGE 12A,3X,8A,2X,11A,2X,12A,3X,9A,6X,8A
210 PRINT USING Format;"Period/P.W./";"Periods";"Timebase";"Source
Noise";"Slew Rate";"Accuracy"
220 PRINT USING Format;"T.I.(sec)";"Averaged";""; "(V rms)";"( V/sec)";
"(sec)"
230 PRINT
240 FOR I = 1 TO Calc_no
250 Format1:IMAGE D.5DE,3X,5D,3X,D.5DE,3X,D.5DE,
3X,D.5DE,3X,2A,D.5DE
260 PRINT USING Format1;Period(I);Nper(I);Timebase(I);Noise(I);
Slewrates(I);CHR$(254);Accuracy(I)
270 NEXT I
280 END
```

Typical Display

Period/Pulse Width/Time Interval Measurement Accuracy (sec)

Period/P.W./ T.I.(sec)	Periods Averaged	Timebase (sec)	Source Noise (V rms)	Slew Rate (V/sec)	Accuracy (sec)
2.00000E-03	128	6.00000E-6	1.00000E-03	1.00000E+04	$\pm 1.38785E-08$

Appendix B

Verification Tests - C Programs

Functional Verification Tests

These programs are designed to do the Functional Verification Tests found in Chapter 3, "Operating Instructions," and Chapter 4, "Verification Tests."

Operator's Check

The Operator's Check for the HP E1333A counter consists of sending the self-test (*TST?) command and checking the return. The operator's check can be used at any time to verify the counter is connected properly and is responding to the self-test command. See Chapter 7, "Service," for a list of counter self-test errors.

As required, see the mainframe user's manual for information on address selection. See the *HP E1333A User's Manual* for information on counter SCPI commands.

```
#include <stdio.h>
#include <scpi.h>

#define ADDR "hpiB7,9,6"          /* Address of Device */

void main ()
{
    INST id;                      /* Define id as an instrument */
    char a[256] = {0};           /* Result variable */
    id = iopen (ADDR);           /* Open instrument session */

    itimeout (id, 10000);        /* Set instrument timeout to 10 seconds */

    ipromptf (id, "**TST?\n", "%t", a); /* Self test command */

    printf ("\n %s", a);         /* Print result */

    getchar ();                  /* Pause */

    iclose (id);                 /* Close instrument session */
}
```

Totalizing Measurement Test

This test verifies the totalize measurement functions on Channels 1 and 2 at 1 Hz and 4 MHz. The test passes if the count increments on each channel. The test fails if the count remains at 0 for either or both channels.

```
/* Totalizing Measurements Functional Test          E1333A */

#include <stdio.h>
#include <siicl.h>

#define ADDR "hpiib7,9,06"                        /* Address of device */

void main ()
{
    INST id;                                       /* Define id as an instrument */
    char *freq;
    int chan, i, timer;
    float reading, counter;
    char cr[256];

    #if defined(__BORLANDC__) && !defined(__WIN32__)
        _InitEasyWin();
    #endif

    ionerror(I_ERROR_EXIT);                       /* Exit on error */

    id = iopen (ADDR);                             /* Open instrument session */

    iprintf (id, "RST\n");
    iprintf (id, "INP:COUP DC\n");
    iprintf (id, "INP:IMP MIN\n");
    printf ("\n\nTotalize Counts");

    for (i = 0; i <= 1; i++)
    {
        if (i == 0) freq = "1 Hz";
        else      freq = "4 MHz";

        for (chan = 1; chan <= 2; chan++)
        {
            printf ("\n\n 1. Set input to channel %u to %s, 50 mV rms sine wave", chan, freq);
            printf ("\n 2. Press ENTER when connections are complete");
            getchar ();

            counter = 0;
            timer = 0;
            printf ("\n\nTotalizing counts for channel %u", chan);
            printf ("\n This will take about 15 seconds");

            iprintf (id, "CONF%u:TOT\n", chan);
            iprintf (id, "INIT%u\n", chan);
            while (counter < 15)
```

```

    {
        timer++;
        fprintf (id, "FETC%u?\n", chan);
        scanf (id, "%f", &reading);
        if (reading > counter)
        {
            counter = reading;
            printf (".");
            timer = 0;
        }
        if (timer > 200)
        {
            printf ("\n\n *** Channel %u FAILED to count ****", chan);
            goto FAIL;
        }
    }

    printf ("\n\nChannel %u PASSED Totalizing Measurements Functional Test for %s",
    chan, freq);
    FAIL:
    }
}

    fclose (id);                                     /* Close instrument session */
}

```

Ratio Measurements Test

This test checks the ratio measurements function of the HP E1333A for Channel 1/Channel 2, using Channel 1 and Channel 2 frequencies and ratios shown in Table 4-1.

```

/* Ratio Measurements Functional Test                E1333A */

#include <stdio.h>
#include <scil.h>
#include <math.h>

#define ADDR "hpiib7,9,06"                          /* Address of device */

void main ()
{
    INST id;                                         /* Define id as an instrument */
    int i;
    float reading[5], freq1[5], freq2[5];
    double freq;
}

```

```

#if defined(__BORLANDC__) && !defined(__WIN32__)
    _InitEasyWin();
#endif

ionerror(I_ERROR_EXIT);          /* Exit on error */

id = iopen (ADDR);               /* Open instrument session */

iprintf (id, "*RST\n");
iprintf (id, "INP:COUP DC\n");
iprintf (id, "INP:IMP MIN\n");

for (i = 2; i <= 6; i++)
{
    iprintf (id, "CONF1:RAT 1E6,1E3\n");
    iprintf (id, "INIT1\n");
    freq = pow (10,i);

    printf ("\n\n 1. Set input to channel 1 to 1 MHz, 50 mV rms sine wave");
    printf ("\n 2. Set input to channel 2 to %lf Hz, 50 mV rms sine wave", freq);
    printf ("\nPress ENTER when connection is complete");
    getchar ();
    iprintf (id, "INIT1\n");
    iprintf (id, "FETC1?\n");
    scanf (id, "%f", &reading[i-2]);

    iprintf (id, "MEAS1:FREQ?\n");
    scanf (id, "%f", &freq1[i-2]);
    iprintf (id, "MEAS2:FREQ?\n");
    scanf (id, "%f", &freq2[i-2]);

}

printf ("\n\n-----");
printf ("\nCh 1 Freq   Ch2 Freq   Ch1/Ch2 Ratio   Ch1/Ch2 Ratio");
printf ("\n                should be       measured\n");

for (i = 0; i <= 4; i++)
    printf ("\n%.0f Hz  %7.0f Hz  %5.0f          %5.0f", freq1[i], freq2[i], freq1[i]/freq2[i],
reading[i]);

fclose (id);                    /*close instrument session */
}

```

Trigger Level Test This test checks the trigger level accuracy on Channel 1 for the -2.56V, 0V, +2.54V and +25.4V trigger levels. Table 4-2 shows the trigger levels measured, the input attenuation level in dB, and the below-level and above-level voltage values for each trigger level.

```

/* Trigger Level Functional Test          E1333A */

#include <stdio.h>
#include <sicl.h>
#include <math.h>

#define ADDR "hpi7,9,06"                /* Address of device */

void main ()
{
    INST id;                            /* Define id as an instrument */
    int i, fail = 0;
    float trig_lev[4] = {-2.56, 0, 2.54, 25.4};
    float low[4] = {-2.836, -.02, 2.266, 22.66};
    float high[4] = {-2.284, .02, 2.814, 28.14};
    float reading, level[4];

    #if defined(__BORLANDC__) && !defined(__WIN32__)
        _InitEasyWin();
    #endif

    ionerror(I_ERROR_EXIT);             /* Exit on error */

    id = iopen (ADDR);                  /* Open instrument session */

    iprintf (id, "*RST\n");
    iprintf (id, "INP:COUP DC\n");
    iprintf (id, "INP:FILT ON\n");
    iprintf (id, "CONF1:TOT\n");
    printf ("\n\nTrigger Level Measurements");

    for (i = 0; i <= 3; i++)
    {
        if (i == 3)
        {
            iprintf (id, "INP:ATT MAX\n");
            level[i] = trig_lev[i] / 10;
        }
        else
        {
            iprintf (id, "INP:ATT MIN\n");
            level[i] = trig_lev[i];
        }
        iprintf (id, "SENS1:EVEN:LEV %f\n", level[i]);

        printf ("\n\nTrigger Level = %f", trig_lev[i]);
    }
}

```

```

printf ("\n\n 1. Set input to channel 1 to %f Volts", low[i]);
printf ("\nPress ENTER when connection is complete");
getchar ();
fprintf (id, "INIT1\n");
fprintf (id, "FETC1?\n");
iscanf (id, "%f", &reading);

if (reading > 0)
{
    printf ("\n\n *** Test FAILED for trigger level = %f", trig_lev[i]);
    fail = 1;
}

printf ("\n\n 2. Increase input to channel 1 to %f Volts", high[i]);
printf ("\nPress ENTER when connection is complete");
getchar ();

fprintf (id, "FETC1?\n");
iscanf (id, "%f", &reading);

if (reading <= 0)
{
    printf ("\n\n *** Test FAILED for trigger level = %f", trig_lev[i]);
    fail = 1;
}
}

if (fail == 0) printf ("\n\nAll Trigger Level tests PASSED");
else         printf ("\n\nOne or more Trigger Level tests FAILED");

fclose (id);                                     /* Close instrument session */
}

```

Performance Verification Tests

These programs are designed to do the Performance Verification Tests found in Chapter 4, "Verification Tests."

Frequency Measurements Test

This test checks frequency measurement accuracy on Channels 1, 2, and 3. Input level sensitivity is tested indirectly by using input signals with amplitudes equal to the sensitivity limits.

```
/* Frequency Measurements Test          E1333A */

#include <stdio.h>
#include <sicl.h>

#define ADDR "hplib7,9,06"              /* Address of device */

void main ()
{
    INST id;                             /* Define id as an instrument */
    int chan[24], i;
    float reading[24];
    float aper[24] = {32.768, 16.384, 8.192, 4.096, 2.048, 1.024, .512, .256, .128, .064,
    .032, .016, .008, .004, .002, 65.536, .002, .128, .064, .032, .016, .008, .004, .002};
    float amp[24] = {.025, .025, .025, .025, .025, .025, .025, .025, .025, .025, .025, .025,
    .025, .025, .025, .025, .01, .01, .01, .01, .01, .03, .04};
    float freq[24] = {1.E1, 1.E2, 1.E3, 1.E4, 1.E5, 1.E6, 4.E6, 1.E7, 2.E7, 5.E7, 1.E8, 1.E8,
    1.E8, 1.E8, 1.E8, 1.E8, 1.E8, 7.5E7, 1.E8, 2.E8, 4.E8, 6.E8, 9.E8, 1.E9};

    #if defined(__BORLANDC__) && !defined(__WIN32__)
        _InitEasyWin();
    #endif

    ionerror(I_ERROR_EXIT);              /* Exit on error */

    id = iopen (ADDR);                   /* Open instrument session */

    iprintf (id, "**RST\n");
    iprintf (id, "INP:COUP DC\n");
    iprintf (id, "INP:IMP MIN\n");
    printf ("\n\nFrequency Measurements");

    for (i = 0; i <= 23; i++)
    {
        if (i < 16) chan[i] = 1;
        if (i == 16) chan[i] = 2;
        if (i > 16) chan[i] = 3;
    }
}
```

```

printf ("\n\nFrequency Measurements of channel %u", chan[i]);
printf ("\n Frequency = %f Hz", freq[i]);
printf ("\n Aperture time = %f sec", aper[i]);

printf ("\n\n 1. Set source frequency to %f Hz", freq[i]);
printf ("\n 2. Set source output to %f Volts", ampl[i]);
printf ("\nPress ENTER when ready");
getchar ();

iprintf (id, "SENS%u:FUNC:FREQ\n", chan[i]);
iprintf (id, "SENS%u:FREQ:APER %.3f\n", chan[i], aper[i]);
iprintf (id, "READ%u?\n", chan[i]);
iscanf (id, "%f", &reading[i]);
}

printf ("\n\nFrequency Measurements Performance Test Completed");
printf ("\nPress ENTER to display the results");
getchar ();

printf ("\n\n-----");
printf ("\nCh  Frequency  Aper Time  Measured");
printf ("\n      (Hz)      (sec)      Freq (Hz)\n");
for (i = 0; i <= 23; i++)
    printf ("\n%u    %4f Hz    %6f    %f", chan[i], freq[i], aper[i], reading[i]);

fclose (id);                                /* Close instrument */
}

```

Period Average Measurements

This test measures period averages on Channel 1 only. Period average measurements are made with the frequencies, periods and number of periods averaged shown in Table 4-5. (Channel 2 is not tested since the same circuitry is used for Channels 1 and 2.)

```

/* Period Average Measurements Test          E1333A */

#include <stdio.h>
#include <sicl.h>

#define ADDR "hpi7,9,06"                    /* Address of device */

void main ()
{
    INST id;                                /* Define id as an instrument */
    int i;
    float reading[13];
    int nper[13] = {2, 4, 8, 15, 32, 64, 128, 256, 512, 1024, 2048, 4096, 8192};
}

```



```

char *per[13] = {"1 sec", "100 msec", "10 msec", "1 ms", "200 usec", "100 usec", "20
usec", "10 usec", "2 usec", "1 usec", "500 nsec", "200 nsec", "100 nsec"};
char *freq[13] = {"1 Hz", "10 Hz", "100 Hz", "1 kHz", "5 kHz", "10 kHz", "50 kHz", "100
kHz", "500 kHz", "1 MHz", "2 MHz", "5 MHz", "10 MHz"};

#ifdef __BORLANDC__ && !defined(__WIN32__)
    _InitEasyWin();
#endif

ionerror(I_ERROR_EXIT);                                /* Exit on error */

id = iopen (ADDR);                                    /* Open instrument session */

iprintf (id, "*RST\n");
iprintf (id, "INP:COUP DC\n");
iprintf (id, "INP:IMP MIN\n");
printf ("\n\nPeriod Average Measurements");

for (i = 0; i <= 12; i++)
{
    printf ("\n\nPeriod Average Measurements of channel 1");
    printf ("\n Period = %s", per[i]);
    printf ("\n Periods Averaged = %u", nper[i]);

    printf ("\n\n 1. Set source frequency to %s, 50 mV rms sine wave", freq[i]);
    printf ("\nPress ENTER when ready");
    getchar ();

    iprintf (id, "SENS1:FUNC:PER\n");
    iprintf (id, "SENS1:PER:NPEN %u\n", nper[i]);
    iprintf (id, "READ1?\n");
    scanf (id, "%f", &reading[i]);
}
printf ("\n\nPeriod Measurements Performance Test Completed");
printf ("\nPress ENTER to display the results");
getchar ();

printf ("\n\n-----");
printf ("\nCh Period Periods Measured");
printf ("\n (sec) Averaged Period (sec)\n");
for (i = 0; i <= 12; i++)
    printf ("\n1 %8s %4u %f", per[i], nper[i], reading[i]);

fclose (id);                                          /* Close instrument session */
}

```

Pulse Width Measurements Test

This test measures positive and negative pulse width averages on Channels 1 and 2 at 0.5 Hz and 500Hz. Table 4-6 shows the pulse widths and pulse polarities measured.

```
/* Pulse Width Measurements Test          E1333A */

#include <stdio.h>
#include <sicl.h>

#define ADDR "hpi7,9,06"                  /* Address of device */

void main ()
{
    INST id;                               /* Define id as an instrument */
    int i, chan[8];
    float reading[8];
    float pulse[8] = {1., .001, 1., .001, 1., .001, 1., .001};
    char *pulse_wid[8] = {"1 sec", "1 sec", "1 msec", "1 msec", "1 sec", "1 sec", "1 msec", "1
msec"};
    char *type[8] = {"POS", "NEG", "POS", "NEG", "POS", "NEG", "POS", "NEG"};
    char *freq[8] = {"0.5 Hz", "0.5 Hz", "500 Hz", "500 Hz", "0.5 Hz", "0.5 Hz", "500 Hz", "500
Hz"};
    char *pol[8] = {"PWID", "NWID", "PWID", "NWID", "PWID", "NWID", "PWID", "NWID"};

    #if defined(__BORLANDC__) && !defined(__WIN32__)
        _InitEasyWin();
    #endif

    ionerror(I_ERROR_EXIT);                /* Exit on error */

    id = iopen (ADDR);                     /* Open instrument session */

    fprintf (id, "*RST\n");
    fprintf (id, "INP:COUP DC\n");
    fprintf (id, "INP:IMP MIN\n");
    printf ("\n\nPulse Width Measurements");

    for (i = 0; i <= 7; i++)
    {
        if (i <= 3) chan[i] = 1;
        if (i > 3) chan[i] = 2;

        printf ("\n\nPulse Width Measurements of channel %u", chan[i]);
        printf ("\n Measure %s Pulse Width", type[i]);
        printf ("\n Pulse Width = %s", pulse_wid[i]);
        printf ("\n Periods Averaged = 2");

        printf ("\n\n 1. Set source frequency to %s, 50 mV rms square wave", freq[i]);
        printf ("\nPress ENTER when ready");
        getchar ();
    }
}
```

```

    fprintf (id, "SENS%u:FUNC:%s\n", chan[i], pol[i]);
    fprintf (id, "SENS%u:PER:NPER 2\n", chan[i]);
    fprintf (id, "READ%u?\n", chan[i]);
    fscanf (id, "%f", &reading[i]);
}

printf ("\n\nPulse Width Measurements Performance Test Completed");
printf ("\nPress ENTER to display the results");
getchar ();

printf ("\n\n-----");
printf ("\nCh   Pulse   Pulse   Measured");
printf ("\n   Width  Polarity  Width (msec)\n");
for (i = 0; i <= 7; i++)
    printf ("\n%u   %6s  %3s    %f", chan[i], pulse_wid[i], pol[i], reading[i]);

fclose (id);                                     /* Close instrument session */
}

```

Time Interval Measurements Test

This test checks time interval accuracy on Channels 1 and 2 for the time interval and edges shown in Table 4-7, where POS = rising edge and NEG = falling edge of channel input.

```

/* Time Interval Measurements Test           E1333A */

#include <stdio.h>
#include <siicl.h>

#define ADDR "hpib7,9,06"                   /* Address of device */

void main ()
{
    INST id;                                 /* Define id as an instrument */
    int i, chan[2];
    float reading[2];
    char *slope1[2] = {"POS", "NEG"};
    char *slope2[2] = {"NEG", "POS"};

    #if defined(__BORLANDC__) && !defined(__WIN32__)
        _InitEasyWin();
    #endif

    ionerror(I_ERROR_EXIT);                 /* Exit on error */
}

```

```

id = iopen (ADDR);                                     /* Open instrument session */

iprintf (id, "*RST\n");
iprintf (id, "INP:COUP DC\n");
iprintf (id, "INP:IMP MIN\n");
printf ("\n\nTime Interval Measurements");

for (i = 0; i <= 1; i++)
{
    if (i == 0) chan[i] = 1;
    if (i == 1) chan[i] = 2;

    printf ("\n\nTime Interval Measurements of channel %u", chan[i]);
    printf ("\n From Channel 1 %s edge to Channel 2 %s edge", slope1[i], slope2[i]);
    printf ("\n\n 1. Set source frequency to 1 MHz, 50 mV rms square wave");
    printf ("\nPress ENTER when ready");
    getchar ();

    if (i == 0)
    {
        iprintf (id, "SENS1:FUNC:TINT\n");
        iprintf (id, "SENS1:EVEN:SLOP POS\n");
        iprintf (id, "SENS2:EVEN:SLOP NEG\n");
        iprintf (id, "READ1?\n");
        scanf (id, "%f", &reading[i]);
    }
    if (i == 1)
    {
        iprintf (id, "SENS2:FUNC:TINT\n");
        iprintf (id, "SENS1:EVEN:SLOP NEG\n");
        iprintf (id, "SENS2:EVEN:SLOP POS\n");
        iprintf (id, "READ2?\n");
        scanf (id, "%f", &reading[i]);
    }
}

printf ("\n\nTime Interval Measurements Performance Test Completed");
printf ("\nPress ENTER to display the results");
getchar ();

printf ("\n\n-----");
printf ("\nCh   Time   Ch 1   Ch 2   Measured");
printf ("\n   Interval   Edge   Edge   Interval");
printf ("\n      (nsec)                (nsec)\n");
for (i = 0; i <= 1; i++)
    printf ("\n%u   500      %3s   %3s   %f", chan[i], slope1[i], slope2[i],
reading[i]*(1.E9));

    iclose (id);                                       /* Close instrument session */
}

```

Counter Accuracy Programs

These programs are designed to calculate counter accuracies as described in Appendix A, "Counter Accuracy Calculations."

Frequency Measurement Accuracy

To make frequency measurement accuracy calculations, first enter the desired number of accuracy calculations you want to make (up to 100 sets of calculations). Then, for each calculation enter the desired values for:

- Frequency (Hz)
- Aperi time (sec)
- Timebase
- Source noise (V rms)
- Slew rate (V/sec)

The program calculates frequency measurement accuracy for each set of input values and displays the results.

```
/* Frequency Measurement Accuracy      E1333A */

#include <stdio.h>
#include <math.h>

void main (void)
{
    float freq[100], aper[100], timebase[100], noise[100], slewrate[100], accuracy[100];
    int i;
    float calc = 0;

    printf ("\nSelect number of calculations (1 to 100) ");
    scanf ("%f", &calc);

    for (i = 0; i < calc; i++)
    {
        printf ("\n\nSelect values for frequency accuracy calculation %u", i+1);
        printf ("\n\n Frequency (Hz) = ");
        scanf ("%f", &freq[i]);
        printf ("\n\n Aperi time (sec) = ");
        scanf ("%f", &aper[i]);
        printf ("\n\n Timebase = ");
        scanf ("%f", &timebase[i]);
        printf ("\n\n Source noise (V rms) = ");
        scanf ("%f", &noise[i]);
        printf ("\n\n Slew rate (V/sec) = ");
        scanf ("%f", &slewrate[i]);

        accuracy[i] = 1/aper[i] + timebase[i]*freq[i] + 1.4*freq[i]*(sqrt((pow (8.0E-5,2) + pow
        (noise[i],2)))/(slewrate[i]*aper[i]));
    }
}
```

```

printf ("\n\nFrequency Measurement Accuracy\n\n");
printf ("\nFrequency Aper Time Timebase Source Noise Slew Rate Accuracy");
printf ("\n(Hz) (sec) (V rms) (V/sec) (Hz)\n");
for (i = 0;i < calc;i ++)
    printf ("\n%e %e %e %e %e", freq[i], aper[i], timebase[i], noise[i], slewrate[i],
accuracy[i]);
}

```

Period Measurements Accuracy

To make period/pulse width/time interval accuracy calculations, enter the number of accuracy calculations you want to make (up to 100 sets of calculations). Then, for each calculation enter the desired values for:

- Period/pulse width/time interval (sec)
- Number of periods averaged
- Timebase
- Source noise (V rms)
- Slew rate (V/sec)

The program calculates period, pulse width, or time interval measurement accuracy for each set of input values and displays the results.

```

/* Period Measurement Accuracy      E1333A */

#include <stdio.h>
#include <math.h>

void main (void)
{
    float period[100], nper[100], timebase[100], noise[100], slewrate[100], accuracy[100];
    int i, calc = 0;

    printf ("\nSelect number of calculations (1 to 100) ");
    scanf ("%u", &calc);

    for (i = 0;i < calc;i ++)
    {
        printf ("\n\nSelect values for period/PW/TI accuracy calculation %u", i+1);
        printf ("\n\n Period/pulse width/Time interval (sec) = ");
        scanf ("%f", &period[i]);
        printf ("\n\n Number of periods averaged = ");
        scanf ("%f", &nper[i]);
        printf ("\n\n Timebase = ");
    }
}

```

```

scanf("%f", &timebase[i]);
printf ("\n Source noise (V rms) = ");
scanf("%f", &noise[i]);
printf ("\n Slew rate (V/sec) = ");
scanf("%f", &slewrates[i]);

accuracy[i] = 1.E-7 / nper[i] + timebase[i]*period[i] + 1.4*(sqrt((pow(8.0E-5,2) +
pow(noise[i],2)))/(nper[i]*slewrates[i]));
}

printf ("\n\nPeriod/Pulse width/Time interval Measurement Accuracy\n\n");
printf ("\nPeriod/PW/  Periods  Timebase  Source Noise  Slew Rate  Accuracy");
printf ("\nTI (Hz)      (sec)          (V rms)      (V/sec)      (sec)\n");
for (i = 0; i < calc; i++)
    printf ("\n%e %e %e %e %e %e", period[i], nper[i], timebase[i], noise[i], slewrates[i],
accuracy[i]);
}

```

Notes